

Optical Systems

Active and passive components



braun teleCom products have stood for competence and continuity for more than 35 years. Extensive experience and constantly growing know-how make the components and systems an integral part of many FTTH and HFC broadband networks.

While, in many areas, our activities focus on the development and production of our own products, we also serve as distributor for selected high-performance partners to achieve best possible customer satisfaction.

braun teleCom is a product brand of Netceed. We are a global leader in distribution, logistics, technical engineering, and product design with over 30 years of expertise and performance supporting the telecommunications and broadband industry.

Netceed is a global leader in distribution, logistics, technical engineering, and product design supporting the telecommunications and broadband industry. We supply and distribute a comprehensive range of passive and active equipment and tooling for network deployment, upgrades, and maintenance, supporting all technologies including FTTH, FTTx, HFC, Wi-Fi, 5G/mobile, and data center.

Netceed's comprehensive portfolio of 90,000+ products from nearly 1,500 industry-leading suppliers, along with their value-added supply chain solutions support carriers' seamless delivery of high-speed Internet, Video, Data, and Voice services to Residential, Business, and Mobile Users.



CONTENT

1. COAXIAL TECHNOLOGY

2. CABINETS AND ACCESSORIES FOR POWER SUPPLY

3. OPTICAL SYSTEMS

Active optical components 3

Optical transmitters	5
Optical amplifiers	10
RFoG optical return path receiver	16
Optical switch	17
Optical receivers	18
Gateways / ONTs	19

Passive optical components 21

Splice splitter patch outdoor cabinets	22
ODF systems	25
19" splice panels	26
19" housings for PLC splitters and multiplexers	28
PLC mini splitter modules	29
CWDM multiplexers	30
Fiber-optic cable	35
Speedpipes, micro tubes and accessories	42
House infeeds	45
Patch cords	46
Pigtails	48
Adapters and attenuators	49
Termination boxes for buildings	50
Termination boxes for apartments	57
Closures	63
Installation accessories and splice protection	65

4. TOOLS

5. CLICK & GO

6. AUTHORIZED DISTRIBUTION

ACTIVE OPTICAL COMPONENTS

Do you have questions concerning our products or want to place an order?

We look forward to your call!
+49 511 757086

Do you already know, which products you need?
shop.brauntelecom.com

Various possible combinations

of our active optical components

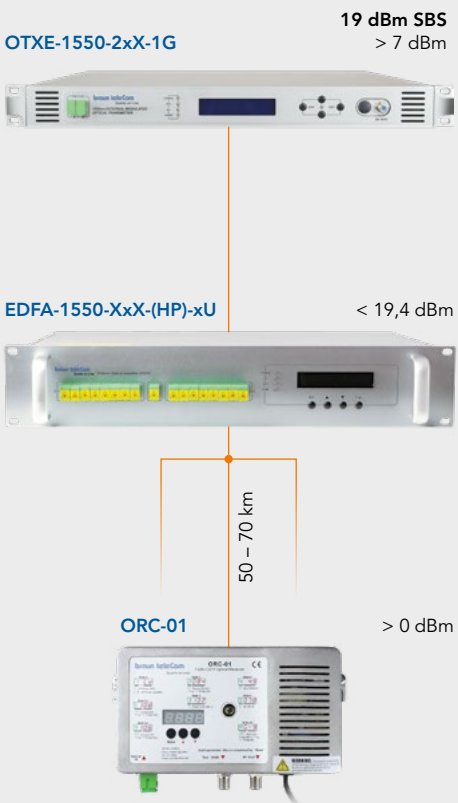
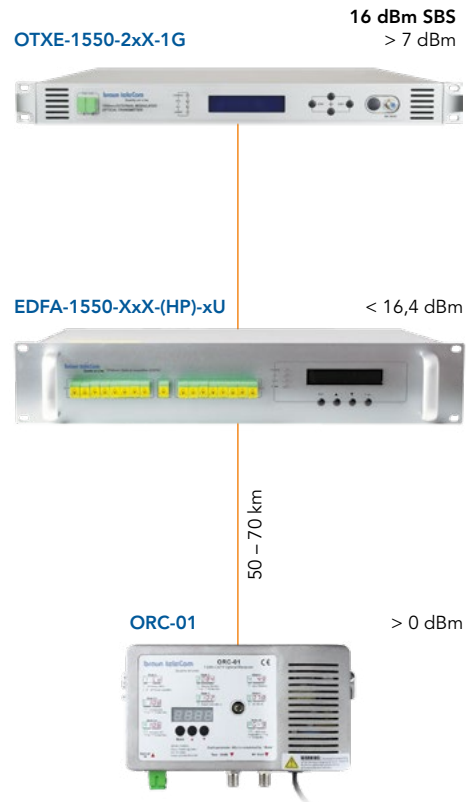
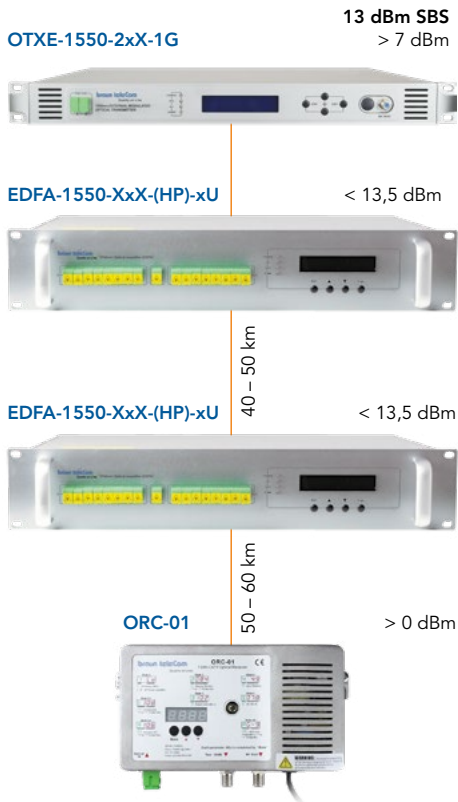

Network example with EPON OLT and HF Broadcast

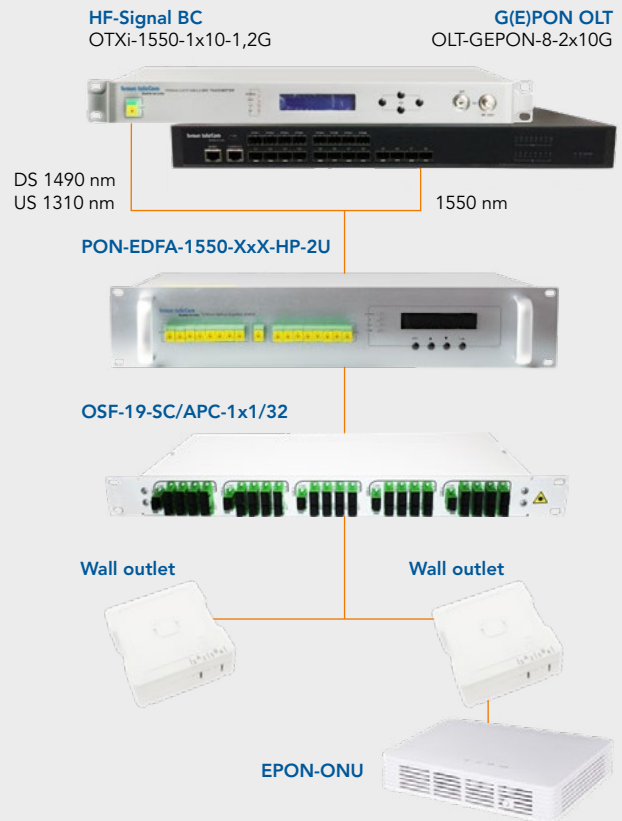

Subject to technical changes!

Optical transmitters

1550 nm directly modulated optical transmitter (45 – 1.218 MHz)

10420211
OTXi-1550-1xX-1,2G



- Cost effective 1550 nm optical transmitter for use in HFC networks with short fiber lengths and modest requirements
- Conversion of RF signals in amplitude-modulated optical signals for the forward path in CATV HFC networks
- Equipped with either ORTEL or AOI DFB lasers for a very good linearity and high optical output power
- Independently developed digital automatic processing technology in the RF drive part, automatic processing of the drive level power according to the actual RF input signal level and the channel loading to ensure the optimal value of system parameters
- Advanced multi-frequency RF pre-distortion technology, combined with GaAs amplifier stages, ensures an effective improvement of the system parameters
- Advanced 32 bit processor, built-in blue screen 160 x 32 dot matrix LCD monitor
- System parameter setting by front panel keypad, serial interface (RS 232) or user-friendly web interface
- SNMP network management functionality via RJ 45 interface
- 2 power supplies, each with 50 % load sharing, in case one power supply fails the second takes over 100 %
- Dimensions: 19"/1RU (483 x 370 x 44 mm (W x D x H))
- Weight: approx. 3,7 kg
- Connector types: SC/APC (optical) and F-females (RF and test point) – E2000/APC alternative available
- Ready for DOCSIS® 3.1

Parameter	Frequency [MHz]	OTXi-1550-1xX-1,2G
Operating wavelength [nm]		1550 ± 20
Optical output power [mW/dBm]		10/10
Optical return loss [dB]		≥ 50
RF frequency range [MHz]		45 – 1.218
RF input level range [dBμV]		72 ... 88
Frequency response [dB]		± 0,75
AGC control range [dB]		± 5
MGC control range [dB]		0 – 10
Return loss [dB]	45 – 550	≥ 16
	550 – 1.218	≥ 14
System parameters		42 channels CENELEC, 4 % OMI, 20 km fiber length, Rx = 0 dBm
Composite Second Order (CSO) [dB]		≥ 60
Composite Triple-Beat (CTB) [dB]		≥ 63
Carry-to-Noise (C/N) [dBc]		≥ 48
Optical connectors		SC/APC
Supply voltage [VAC]		2 x 110 – 250/50 Hz (50 – 50 load sharing)
Power consumption [W]		< 30
Operating temperature range [°C]		0 ... +45
Storage temperature range [°C]		-20 ... +65
Max. relative humidity (operation and storage)		max. 95 %, no condensation
Order No.		10420211

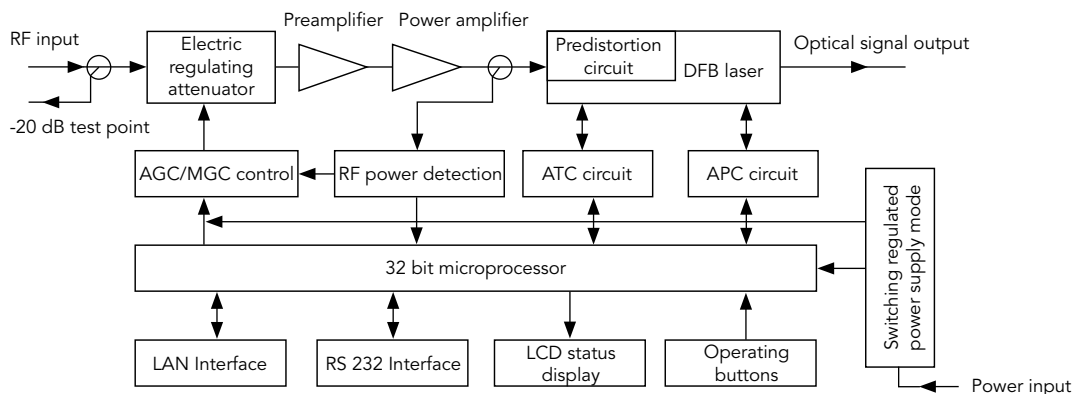

1550 nm externally modulated optical transmitter (47 – 1.006 MHz)

10420328
OTXE-1550-2x8-1G



- Narrowband and very low noise DFB laser for a very good linearity and excellent system parameters
- Designed for the operation with optical amplifiers (normal-power EDFAs and high-power EDFAs)
- Suitable for the realization of optical transmission links of over 100 km
- Setting of an automatic gain control (AGC) or a manual gain control (MGC)
- Perfect SBS suppression circuit, adjustable SBS threshold
- Optical modulator with 2 optical outputs
- 2 fans with intelligent fan control for a very long lifespan and reduction of power consumption
- Advanced 32 bit processor, LCD display
- System parameter setting by front panel keypad, user-friendly web interface or serial interface (RS 232)
- SNMP network management functionality via RJ 45 interface
- 2 redundant and hot-pluggable power supplies each with 50 % load sharing, in case one power supply fails the second takes over 100 %
- Dimensions: 19"/1RU (483 x 455 x 44 mm (W x D x H))
- Weight: approx. 5,5 kg
- Connector types: SC/APC (optical) and F-females (RF and test point) – E2000/APC alternative available

Parameter	OTXE-1550-2x8-1G	OTXE-1550-2x10-1G
Operating wavelength [nm]	1545 ... 1560	1545 ... 1560
Wavelength adjustment range [GHz]	± 50	± 50
Output power per port [dBm]	8	10
Amount of output ports	2	2
Equivalent noise intensity (RIN) [dBc/Hz]	< -160	< -160
Side Mode Suppression Ratio (SMSR) [dB]	> 30	> 30
SBS threshold value [dBm]	+13 ... +19 (continuously adjustable)	+13 ... +19 (continuously adjustable)
Laser linewidth [MHz]	0,3	0,3
RF frequency range [MHz]	47 – 1.006	47 – 1.006
RF input level range [dBμV]	78 ... 96 (AGC mode)	78 ... 96 (AGC mode)
Frequency response [dB]	± 0,75	± 0,75
System parameters		
Composite Second Order (CSO)/ Composite Triple Beat (CTB) [dBc]	≥ 64/≥ 65	≥ 64/≥ 65
Carry-to-Noise (C/N) [dBc]	≥ 55,5	≥ 55,5
Return loss [dB]	≥ 16	≥ 16
AGC control range [dB]	± 3	± 3
MGC control range [dB]	0 – 15	0 – 15
Operating temperature range [°C]	-5 ... +45	-5 ... +45
Storage temperature range [°C]	-30 ... +70	-30 ... +70
Max. relative humidity (operation and storage)	max. 95 %, no condensation	max. 95 %, no condensation
Supply voltage		
Optical connectors	SC/APC	SC/APC
Power consumption [W]	< 60	< 60
Order No.	10420328	10420330

A practical example as well as a block diagram of the 1550 nm externally modulated optical transmitters can be found on the following page.

10420330
OTXE-1550-2x10-1G



Practical example of CSO, CTB, and C/N as a function of SBS

Testing conditions: RF Mode = AGC, RF input level = 80 dB μ V, Rx input power = 0 dBm, EDFA with 5 dB noise figure

Test name	SBS	1st stage EDFA	1st fiber cable length	2nd stage EDFA	2nd fiber cable length	optical receiver input power
Tx/Rx	13,5 dBm	none	none	none	none	0 dBm
Link 1	13,5 dBm	none	35 km	none	none	0 dBm
Link 2	16 dBm	16 dBm	65 km	none	none	0 dBm
Link 3	13 dBm	13 dBm	50 km	13 km	50 km	0 dBm

Test model	C42	D59	D84	D30
Channel plan	CENELEC 42	PAL D59	PAL D84	PAL D
Channel number TV/FM/QAM64	42/0/0	59/0/0	84/0/0	30/0/48
Bandwidth noise [dBc]	5	5	5	5
C/N Tx/Rx [dBc]	55,5	54	52,5	54,5
C/N Link 1 [dBc]	55	53,5	52	54
C/N Link 2 [dBc]	53	52,5	50,5	52,5
C/N Link 3 [dBc]	50,5	50,5	49	51
CSO Tx/Rx and Link 1 [dBc]	64	65	65	70
CSO Link 2 [dBc]	63	65	65	70
CSO Link 3 [dBc]	62	64	63	65
CTB [dBc]	65	65	65	68

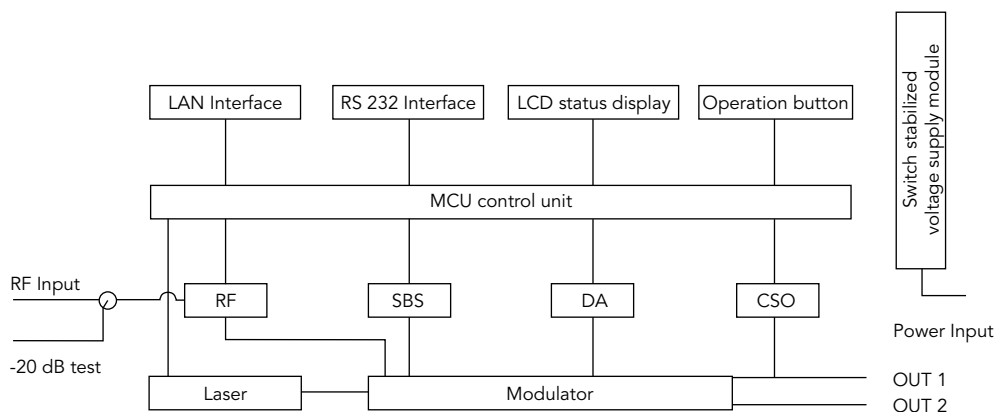

OTX-1310-1xX-1G directly modulated transceivers (45 – 1.006 MHz)

10420409
OTX-1310-1x8-1,2G

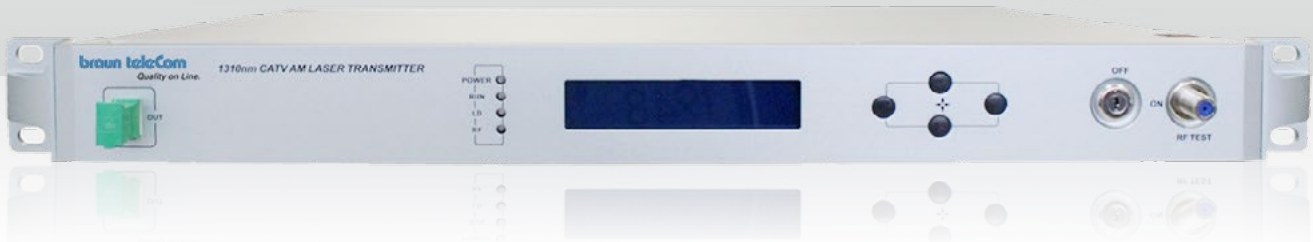

- Cost effective 1310 nm optical transmitter for use in HFC networks with short fiber lengths and modest requirements
- Conversion of RF signals in amplitude-modulated optical signals for the forward path in CATV HFC networks
- Equipped with high-performance coaxial DFB laser for a very good linearity and high optical output power
- Advanced multi-frequency RF pre-distortion technology, combined with GaAs amplifier stages, ensures an effective improvement of the system parameters
- Advanced 32 bit processor, built-in blue screen 160 x 32 dot matrix LCD monitor
- System parameter setting by front panel keypad, serial interface (RS 232) or user-friendly web interface
- SNMP network management functionality via RJ 45 interface
- 2 power supplies, each with 50 % load sharing, in case one power supply fails the second takes over 100 %
- Dimensions: 19"/1RU (483 x 370 x 44 mm (W x D x H))
- Weight: approx. 3,7 kg
- Connector types: SC/APC (optical) and F-females (RF and test point) – E2000/APC alternative available
- Ready for DOCSIS 3.1

Parameter	OTX-1310-1x8-1,2G	OTX-1310-1x10-1,2G	OTX-1310-1x12-1,2G	OTX-1310-1x14-1,2G
Operating wavelength [nm]	1310 ± 20	1310 ± 20	1310 ± 20	1310 ± 20
Optical output power [mW]	6	10	16	26
Optical output power [dBm]	8	10	12	14
Optical link loss [dB]	9	11	13	15
Optical return loss [dB]	≥ 50	≥ 50	≥ 50	≥ 50
RF frequency range [MHz]	45 – 1.218	45 – 1.218	45 – 1.218	45 – 1.218
RF input level range [dBμV]	75 ... 85	75 ... 85	75 ... 85	75 ... 85
Frequency response [dB]	± 0,75	± 0,75	± 0,75	± 0,75
AGC control range [dB]	± 5	± 5	± 5	± 5
MGC control range [dB]	0 – 10	0 – 10	0 – 10	0 – 10
Return loss [dB]	≥ 16 (45 – 550 MHz) ≥ 14 (550 – 1.218 MHz)			
System parameters	42 channels CENELEC, 4 % OMI, 20 km fiber length, Rx = 0 dBm			
Composite Second Order (CSO)/ Composite Triple Beat (CTB) [dBc]	62/67	62/67	62/67	62/67
Carry-to-Noise (C/N) [dBc]	52	52	52	52
Optical connectors	SC/APC	SC/APC	SC/APC	SC/APC
Supply voltage	2 x 110 – 250/50 Hz (each 50 % load sharing)			
Power consumption [W]	< 30	< 30	< 30	< 30
Operating temperature range [°C]	0 ... +45	0 ... +45	0 ... +45	0 ... +45
Storage temperature range [°C]	-20 ... +65	-20 ... +65	-20 ... +65	-20 ... +65
Max. relative humidity (operation and storage)	max. 95 %, no condensation	max. 95 %, no condensation	max. 95 %, no condensation	max. 95 %, no condensation
Order No.	10420409	10420411	10420413	10420415

Further OTX models are available on request!

The optical link carrier to noise ratio degradation as well as a block diagram of the 1310 nm optical transmitters can be found on the following page.

10420413
OTX-1310-1x12-1G

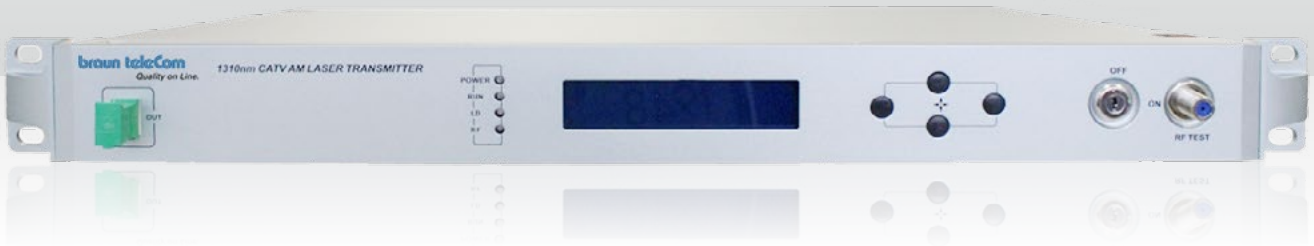

Optical link carrier to noise ratio degradation

Optical power	Optical link loss [dB]																	
	4	5	6	7	8	9	10	11	12	13	14	15	16	17	18			
6 mW				53,0	52,0	51,0	50,1	49,1	48,1									
10 mW						52,9	51,9	51,0	50,1	49,1	48,2							
16 mW									52,0	51,0	50,1	49,1	48,1					
26 mW											51,5	50,2	49,2	48,5	47,6			

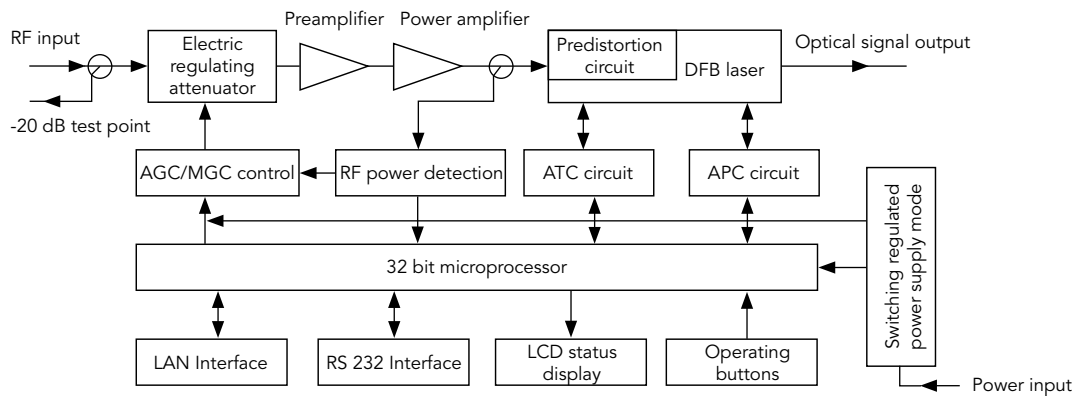

Subject to technical changes!

Optical amplifiers

EDFA-1550-XxX-HP-1U high power optical amplifiers

10420718
EDFA-1550-4x18-HP



- Adopts erbium ytterbium co-doped double-clad fiber technology
- 4 – 16 output ports
- Extremely high optical output power per port
- Adjustable loss at the output -3 – 0 dB
- Low noise figure
- Network management interface, in line with standard SNMP network management
- Intelligent temperature control system for lowering the power consumption
- RS 232 and RJ 45 control interface
- System parameter setting by front panel keypad, serial interface (RS 232) or user-friendly web interface
- 2 power supplies with each 50 % load sharing, 160 ... 250 VAC or 48 VDC, not hot-pluggable
- Connector types: SC/APC (optical) – E2000/APC alternative available

Parameter	EDFA-1550-4x18-HP	EDFA-1550-4x21-HP	EDFA-1550-8x18-HP	EDFA-1550-8x21-HP	EDFA-1550-16x18-HP	EDFA-1550-16x20-HP
Operating wavelength [nm]	1545 – 1565					
Optical input power range [dBm]	-3 ... +10					
Max internal output power [dBm]	25	28	29	32	33	35
Amount output ports	4	4	8	8	16	16
Output power per port [dBm]	18	21	18	21	18	20
Output power stability [dBm]	± 0,5					
Return loss optical output [dB]	≥ 45					
Return loss optical input [dB]	≥ 45					
Noise figure [dBμV]	≤ 5					
Optical connectors	SC/APC					
Power consumption [W]	30					
Operating temperature range [°C]	-10 ... +45					
Storage temperature range [°C]	-30 ... +70					
Max. relative humidity (operation and storage)	max. 95 %, no condensation					
Dimensions (L x W x H) [mm]	483 x 475 x 44					
Weight [kg]	3,7					
Rack unit	19"/1 RU					
Order No.	10420718	10420721	10420738	10420741	10420818	10420754

Further EDFA models are available on request!

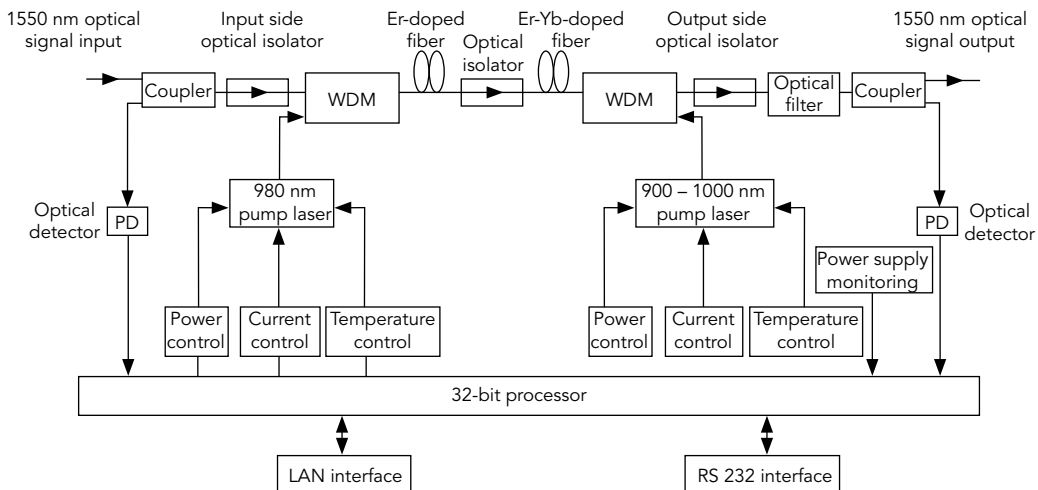

EDFA-1550-XxX-HP-2U high power optical amplifiers

10420821
EDFA-1550-16x21-HP-2U

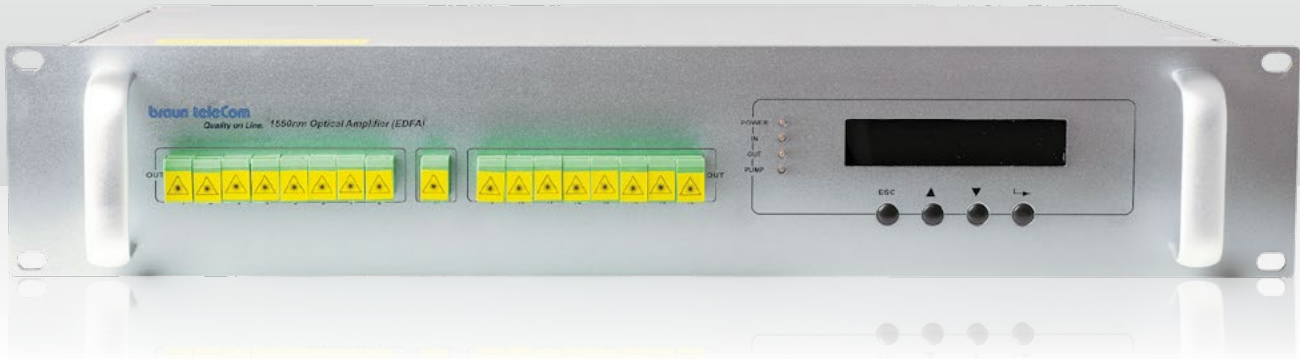

- Adopts erbium ytterbium co-doped double-clad fiber technology
- 4 – 32 output ports
- Extreme high optical output power per port
- Adjustable loss at the output 0 – 3 dB
- Low noise figure
- Network management interface, in line with standard SNMP network management
- Intelligent temperature control system for lowering the power consumption
- System parameter setting by front panel keypad, serial interface (RS 232) or user-friendly web interface
- RS 232 and RJ 45 control interface
- 2 power supplies with each 50 % load sharing, 160 ... 250 VAC or 48 VDC, hot-pluggable
- Connector types: SC/APC (optical) – E2000/APC alternative available

Parameter	EDFA-1550-16x21-HP-2U	EDFA-1550-32x18-HP-2U	EDFA-1550-64x18-HP-2U
Operating wavelength [nm]		1545 – 1565	
Optical input power range [dBm]		-3 ... +10	
Max internal output power [dBm]	36	33	37
Amount output ports	16	32	64
Output power per port [dBm]	21	18	18
Output power stability [dBm]		± 0,5	
Return loss optical output [dB]		≥ 45	
Return loss optical input [dB]		≥ 45	
Noise figure [dBμV]		≤ 5	
Optical connectors		SC/APC	
Power consumption [W]		30	
Operating temperature range [°C]		-10 ... +45	
Storage temperature range [°C]		-30 ... +70	
Max. relative humidity (operation and storage) [%]		max. 95 %, no condensation	
Dimensions (L x W x H) [mm]		434 x 456 x 87	
Weight [kg]		6,8	
Rack unit		19" / 2 RU	
Order No.	10420821	10420828	10420837

Further EDFA models are available on request!

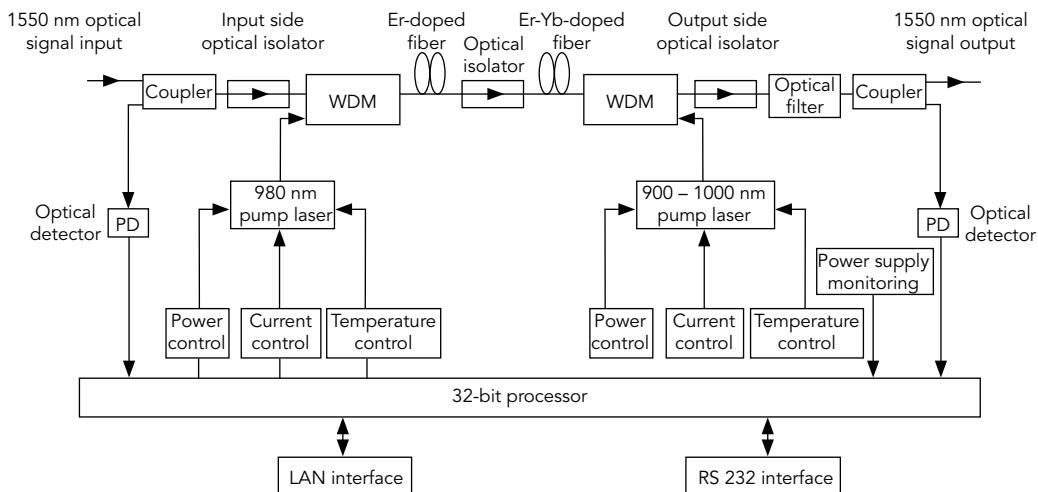

Subject to technical changes!

EDFA-1550-XxX optical amplifiers

10420648
EDFA-1550-2x18



- High-performance erbium doped fiber and low noise pump laser
- 1 – 4 output ports
- Extremely high optical output power per port
- Adjustable loss at the output -3 – 0 dB
- Low noise figure
- Network management interface, in line with standard SNMP network management
- Intelligent temperature control system for lowering the power consumption
- System parameter setting by front panel keypad, serial interface (RS 232) or user-friendly web interface
- RS 232 and RJ 45 control interface
- 2 power supplies with each 50 % load sharing, 160 ... 250 VAC or 48 VDC, hot-pluggable
- Connector types: SC/APC (optical) – E2000/APC alternative available

Parameter	EDFA-1550-1x18	EDFA-1550-1x20	EDFA-1550-1x21	EDFA-1550-2x18	EDFA-1550-2x21	EDFA-1550-4x17
Operating wavelength [nm]	1545 – 1565					
Optical input power range [dBm]	-3 ... +10					
Max internal output power [dBm]	18	20	21	22	25	24
Amount output ports	1	1	1	2	2	4
Output power per port [dBm]	18	20	21	18	21	17
Output power stability [dBm]	± 0,5					
Return loss optical output [dB]	≥ 45					
Return loss optical input [dB]	≥ 45					
Noise figure [dBμV]	≤ 5					
Optical connectors	SC/APC					
Power consumption [W]	30					
Operating temperature range [°C]	-5 ... +55					
Storage temperature range [°C]	-30 ... +70					
Max. relative humidity (operation and storage)	max. 95 %, no condensation					
Dimensions (L x W x H) [mm]	483 x 420 x 44					
Weight [kg]	3,7					
Rack unit	19"/1 RU					
Order No.	10420608	10420610	10420611	10420648	10420651	10420717

Further EDFA models are available on request!

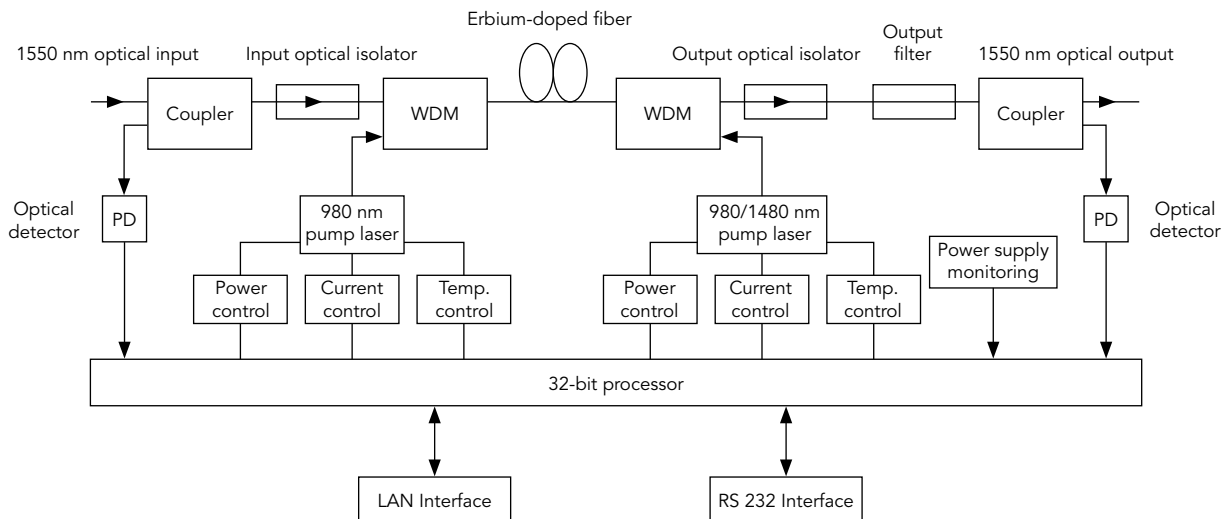

PON-EDFA-1550-XxX-HP-2U high power optical amplifiers

10420822
PON-EDFA-1550-16x21-HP-2U

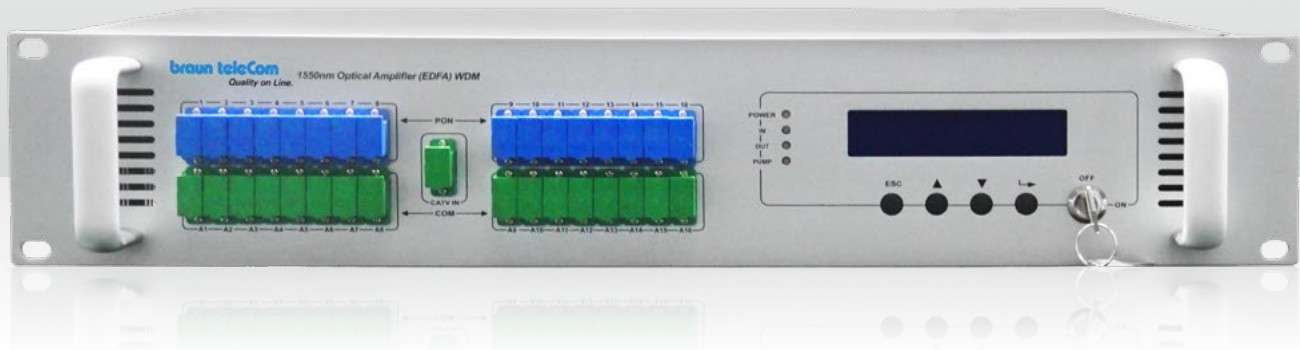

- Adopts erbium ytterbium co-doped double-clad fiber technology
- Extremely high optical output power per port
- Adjustable loss at the output 0 – 3 dB
- Low noise figure
- **With integrated anyPON WDM, 1270/1310/1490/1577 nm per output**
- Network management interface, in line with standard SNMP network management
- Intelligent temperature control system for lowering the power consumption
- System parameter setting by front panel keypad, serial interface (RS 232) or user-friendly web interface
- RS 232 and RJ 45 control interface
- 2 power supplies with each 50 % load sharing, 160 ... 250 VAC or 48 VDC, hot-pluggable
- Connector types: CATV and COM SC/APC – xPON: SC/PC or CATV and COM:LC/APC; xPON: LC/PC

Parameter	PON-EDFA-1550-8x18-HP-2U	PON-EDFA-1550-8x21-HP-2U	PON-EDFA-1550-16x18-HP-2U	PON-EDFA-1550-16x21-HP-2U	PON-EDFA-1550-32x18-HP-2U	PON-EDFA-1550-32x21-HP-2U	PON-EDFA-1550-64x18-HP-2U-LC
CATV wavelength [nm]	1545 – 1565						
xPON wavelength [nm]	1260 – 1360, 1460 – 1500, 1575 – 1581, 1610 – 1650						
WDM through loss [dB]	< 1,0						
Optical input power range [dBm]	-3 ... +10						
Amount output ports	8	8	16	16	32	32	64
Output power per port [dBm]	18	21	18	21	18	21	18
Output power stability [dBm]	± 0,5						
Return loss optical output [dB]	≥ 45						
Return loss optical input [dB]	≥ 45						
Noise figure [dBμV]	≤ 5						
Optical connectors	SC/APC; xPON IN – SC/PC	SC/APC; xPON IN – SC/PC	SC/APC; xPON IN – SC/PC	SC/APC; xPON IN – SC/PC	SC/APC; xPON IN – SC/PC	SC/APC; xPON IN – SC/PC	LC/APC; xPON IN – LC/PC
Power consumption [W]	30						
Operating temperature range [°C]	-10 ... +45						
Storage temperature range [°C]	-30 ... +70						
Max. relative humidity (operation and storage)	max. 95 %, no condensation						
Dimensions (L x W x H) [mm]	434 x 456 x 87						
Weight [kg]	6,8						
Rack unit	19"/2 RU						
Order No.	10420861	10420864	10420815	10420822	10420829	10420824	10420833

Further PON EDFA models are available on request!

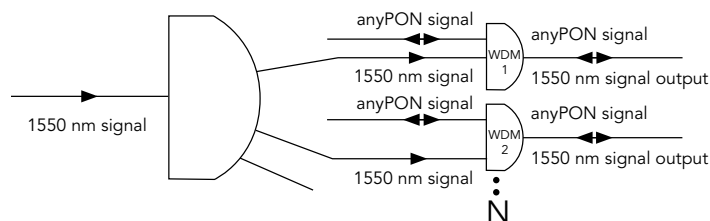

H-EDFA-1550-XxX optical amplifiers for outdoor cabinets

10420920
H-EDFA-1550-8x20-X



- Due to enhanced operation temperature range (-30°C ... +65°C) optimized for installation in outdoor cabinets
- Innovative cooling concept guarantees reliable temperature control in harsh environments
- Space saving design due to 45° angled optical connectors at the front side, also ensuring a low bend radius of the applied patchcords
- Compact design with only 24 cm of installation depth for usage within street cabinets
- Adopts erbium ytterbium co-doped double-clad fiber technology
- Extremely high optical output power per port
- Output power is adjustable from -3 to 0 dB
- Low noise figure
- Network management interface, in line with standard SNMPv2/v3 network management
- Intelligent temperature control system for lowering the power consumption and extending the product's lifespan
- System parameter setting via front panel keypad, serial interface (RS 232) or user-friendly web interface (HTTPS)
- RS 232 and RJ 45 control interface
- 2 hot-swappable power supplies with each 50 % load sharing, 160 ... 250 VAC or 48 VDC
- Optional redundancy switch at the input of the EDFA
- Filter replaceable from the front

Parameter	H-EDFA-1550-8x20-X	H-EDFA-1550-16x20-X	H-EDFA-1550-32x18-XLC
CATV wavelength [nm]		1540 – 1563	
Optical input power range [dBm]		-10 ... +10	
Internal output power [dBm]	31	35	36
Amount of output ports	8	16	32
Output power per port [dBm]	20	20	18
Optical output power [dBm]		≥ 17	
Amount of input ports		1	
Insertion loss [dB]		≤ 1,0	
Output power stability [dBm]		≤ ± 0,3	
Return loss optical output [dB]		≥ 50	
Return loss optical input [dB]		≥ 50	
RF test point [dB typ.]		≥ 78	
Noise figure [dBμV]		≤ 5,5	
Optical connectors	SC/APC	SC/APC	LC/APC
Power supplies		2 x 230 VAC	
Power consumption [W]		50	
Operating temperature range [°C]		-30 ... +65	
Storage temperature range [°C]		-40 ... +80	
Max. relative humidity [%]		95	
Dimensions (L x W x H) [mm]		240 x 482 x 87	
Weight [kg]		6	
Rack Unit		19"/2 RU	
Order-No.	10420940	10420941	10420942

Further Hardened EDFA models are available on request!

H-PON-EDFA-1550-XxX optical PON amplifiers for outdoor cabinets

10420877

H-PON-EDFA-DC-1550-32x18-XLC



- Due to enhanced operation temperature range (-30°C ... +65°C) optimized for installation in outdoor cabinets
- Innovative cooling concept guarantees reliable temperature control in harsh environments
- Space saving design due to 45° angled optical connectors at the front side, also ensuring a low bend radius of the applied patchcords
- Compact design with only 24 cm of installation depth for usage within street cabinets
- **With integrated anyPON WDM, 1270/1310/1490/1577 nm per output**
- Adopts erbium ytterbium co-doped double-clad fiber technology
- Extremely high optical output power per port
- Output power is adjustable from -3 to 0 dB
- Low noise figure
- Network management interface, in line with standard SNMPv2/v3 network management
- Intelligent temperature control system for lowering the power consumption and extending the product's lifespan
- System parameter setting via front panel keypad, serial interface (RS 232) or user-friendly web interface (HTTPS)
- RS 232 and RJ 45 control interface
- 2 hot-swappable power supplies with each 50 % load sharing, 160 ... 230 VAC or 48 VDC
- Optional redundancy switch at the input of the EDFA
- Filter replaceable from the front

Parameter	H-PON-EDFA-1550-8x18-X	H-PON-EDFA-1550-8x20-X	H-PON-EDFA-1550-16x18-X	H-PON-EDFA-1550-16x20-X	H-PON-EDFA-1550-32x18-XLC	H-PON-EDFA-DC-1550-32x18-XLC
CATV wavelength [nm]	1540 – 1563					
xPON wavelength [nm]	1260 – 1360, 1460 – 1500, 1575 – 1581, 1610 – 1650					
WDM through loss [dB]	< 1,0					
Optical input power range [dBm]	-10 ... +10					
Internal output power [dBm]	29	31	33	35	36	36
Amount of output ports	8	8	16	16	32	32
Output power per port [dBm]	18	20	18	20	18	18
Optical output power [dBm]	≥ 17					
Amount of input ports	1					
Insertion loss [dB]	≤ 1,0					
Output power stability [dBm]	≤ ± 0,3					
Return loss optical output [dB]	≥ 50					
Return loss optical input [dB]	≥ 50					
RF test point [dB typ.]	≥ 78					
Noise figure [dBμV]	≤ 5,5					
Optical connectors	SC/APC; xPON IN – SC/PC	SC/APC; xPON IN – SC/PC	SC/APC; xPON IN – SC/PC	SC/APC; xPON IN – SC/PC	LC/APC; xPON IN – LC/PC	LC/APC; xPON IN – LC/PC
Power supplies	230 VAC	230 VAC	230 VAC	230 VAC	230 VAC	48 VDC
Power consumption [W]	50					
Operating temperature range [°C]	-30 ... +65					
Storage temperature range [°C]	-40 ... +80					
Max. relative humidity [%]	95					
Dimensions (L x W x H) [mm]	240 x 482 x 87					
Weight [kg]	6					
Rack Unit	19"/2 RU					
Order-No.	10420943	10420944	10420945	10420946	10420935	10420936

Further Hardened PON EDFA models are available on request!

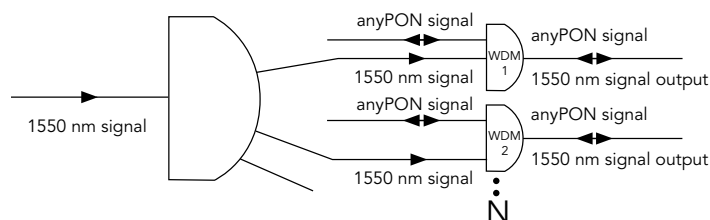

RFoG optical return path receiver

ORX-4C-200 RFoG

10420092
ORX-4C-200 RFoG



- Designed for converting optical upstream signals into RF signals in head-ends and hubs, especially for usage in RFoG network topologies
- Supports Docsis 3.0 upstream channel bonding in PON architectures
- 4 separate optical return path receivers in one compact device
- Connection of up to 256 optical RFoG micro nodes (e.g. 4 clusters with each 64 RFoG micro nodes)
- Microprocessor-controlled adjustment of system parameters using frontal keypads or via a web interface (RJ 45 or RS 232)
- **The device is switchable from "RFoG" mode to "normal" mode (continuous light at the entrance)**
- Monitoring of the optical input power via web interface in "normal" mode
- Extremely high input sensitivity
- Very high RF output level for each receiver, depending on the relevant optical input level
- Fine tuning of the RF output level for each receiver by using internal attenuators
- Optical status indication with LEDs and built-in LCD monitor
- Separate test points for measuring the RF output levels (front side)
- Extremely wide operating temperature range, thereby suitable in almost all environmental conditions
- 2 power supplies with each 50 % load sharing, in case of a failure of one power supply 100 % load transfer to the 2nd power supply
- Connector types: SC/APC (optical) and F-females (RF and test points) – E2000/APC alternative available

Parameter	ORX-4C-200 RFoG
Operating wavelength [nm]	1200 ... 1620
Optical input power range [dBm]	-27 ... -13
Equivalent noise current input [pA/√Hz]	1
Optical return loss [dB]	> 50
Test point per RF output [dB]	-20 ± 0,5
Return loss output [dB]	> 16
Return loss optical input [dB]	≥ 45
RF frequency range [MHz]	5 – 200
RF output level per receiver [dBμV]	90 ... 120 (e.g.: 98 dBμV at 10 % OMI, -27 dBm , ATT. = 0 dB)
Frequency response [dB]	± 0,75
Attenuator range per receiver [dB]	-30 ... 0 (in 1 dB steps via front site, in 0,5 dB steps via web interface)
Power consumption [W]	≤ 12
Operating temperature range [°C]	-40 ... +65
Dimensions (L x W x H) [mm]	480 x 325 x 44
Weight [kg]	2,0
Order No.	10420092

Optical switch

1 x 2 optical switch for redundant optical fiber transmissions

10420103
OSW-2



- Extremely short switching time
- Transmission of very high optical powers
- Advanced 32 bit processor for punctual and accurate monitoring of input power, reliable control of switch status and setup of automatic or manual switch mode
- Switches automatically when optical signal has a fault
- System parameters setting by front panel keypad or serial interface (RS 232)
- SNMP network management functionality via RJ 45 interface
- 2 power supplies with each 50 % load sharing, in case one power supply fails the second takes over 100 %
- Built-in blue screen 160 x 32 dot matrix LCD monitor
- SC/APC connectors at the front side
- Dimensions: 19"/1 RU (483 x 285 x 44 mm (W x D x H))
- Weight: approx. 2,0 kg

Parameter	OSW-2
Operating wavelength [nm]	1200 ... 1620
Max. optical input power [dBm]	27
Through loss [dB]	≤ 1,3 (tested at 1310, 1490, 1550 nm)
Return loss output [dB]	> 55
Optical return loss [dB]	> 55
Optical input power ranges [dBm]	-15 ... +24
Max. switching life (MTBF)	≥ 10.000.000
Optical connectors	SC/APC
Supply voltage [VAC]	2 x 160 – 250/50 Hz (each 50 % load sharing)
Power consumption [W]	≤ 2
Operating temperature range [°C]	-5 ... +55
Storage temperature range [°C]	30 ... +70
Order No.	10420103

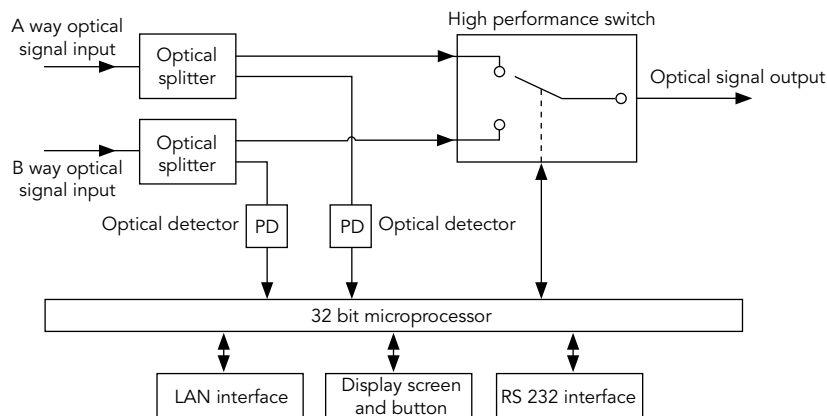

Optical receivers

Optical broadband receivers 45 – 1.006 MHz with high power output for CATV applications



10420060
ORC-01

- Optical status indication by LEDs
- Integrated test point for the RF output
- Very high and constant RF output level within the whole optical input power range by an integrated automatic gain control (AGC)
- Connector types: SC (optical) and F-females
- Dimensions: approx. 190 x 110 x 52 mm (W x H x D)
- Weight: approx. 0,4 kg

Parameter	ORC-01	ORC-01-1550	ORC-01-PON	ORC-01-XPON
Max. optical input power [dBm]			-9 – +2	
Responsivity [A/W]			0,85	
Optical return loss [dB]			45	
Optical connectors input			SC/APC	
Operation bandwidth [MHz]			45 – 1.006	
Output level [dBμV]			110 (-9 +2 dBm i) 112 (-8 +2 dBm i)	
Flatness [dB]			-0,75 – +0,75	
Return loss [dB]			14	
Test point [dB typ.]			-20	
Composite Second Order (CSO) [dB]			60*	
Composite Triple Beat (CTB) [dB]			60*	
Carry-to-Noise (C/N) [dB]			51*	
Supply voltage [VAC]			150 ... 265	
Operating temperature range [°C]			-20 – +55	
Storage temperature range [°C]			-40 – +60	
Power consumption [W]			8	
Operating wavelength [nm]	1100 – 1600	1545 – 1563	1539 – 1565	1539 – 1565
PON pass through (SC/PC) [nm]	-	-	1260 – 1360 1480 – 1500	1270/1310/1490/1577
Order No.	10420060	10420062	10420064	10420066

* At P IN = -1 dBm, P OUT = 106 dBμV, 42 CH CENELEC, OMI = 3,5 %

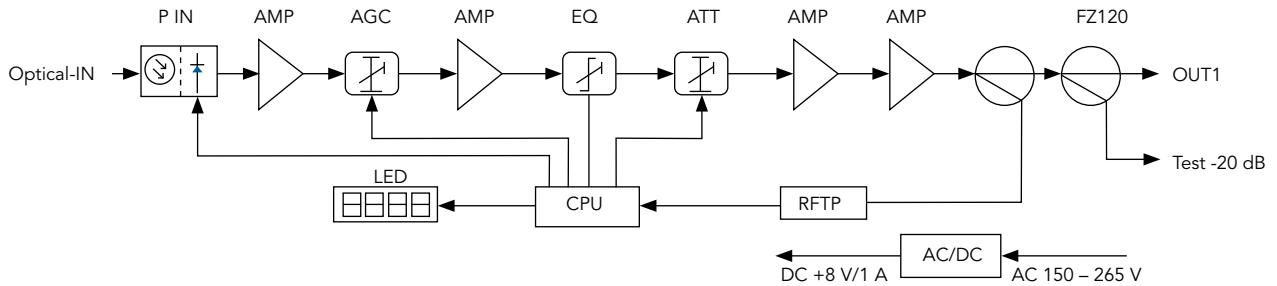

Gateways / ONTs

1 Gbps DKT Gateways



84179740
FTTH-1F-CATV,
image with matching FTU

1 Gbps Gateways

The 1 Gbps gateway series is a unique and innovative product line that distinguishes itself by its small form factor and unique click-on interface. The small form factor, combined with ease of installation due to its click-on interface, makes the gateways an extremely flexible solution, with optimized handling and efficiency.

Parameter	FTTH-1F-CATV	JUMA-1F-WAN-OAM	FTTH-1F-4P-S	FTTH-2F-4P-S-C	FTTH-GPON-1F-1	FTTH-GPON-1F-1/C	FTTH-GPON-1F-4P	FTTH-GPON-1F-4P/C
1 Gbps WAN	(1)	Yes	Yes	Yes	–	–	–	–
GPON WAN	–	–	–	–	Yes	Yes	Yes	Yes
1 Gbps LAN	–	1	4	4	1	1	4	4
CATV	Yes	–	–	Yes	Optional	Optional	Optional	Optional
CATV RF output [dBμV]	84	84	84	84	84	84	84	84
Switch engine(2)	–	Yes	Yes	Yes	Yes	Yes	Yes	Yes
CATV RF filter option	–	–	–	–	Optional	Optional	Optional	Optional
SFP WAN	–	Fixed	Fixed	Fixed	Fixed	Fixed	Fixed	Fixed
Fiber connector	SC/APC	SC/UPC	SC/UPC	SC/UPC & SC/APC	SC/APC	SC/APC	SC/APC	SC/APC
WDM filter	–	–	Optional	Optional	–	–	–	–
WBF blocker	–	–	–	–	–	Ja	–	Ja
GPON quality	–	–	–	–	Class B+	Class C+	Class B+	Class C+
Compatible with click-on FTU TR-069	Yes	Yes	Yes	Yes	Yes	Yes	Yes	Yes
Dimensions with/without cover (H x D x W) [mm]	23/15 x 88 x 88							
Operating temperature range [°C]	0 ... 40							
Ethernet	IEEE 802.1Q VLANs (4k VLANs) incl. Q-in-Q IEEE 802.1Q tag insertion and stripping IGMP v1/2/3 snooping							
QoS	IEEE 802.1p prioritization and reclassification							
Management	OAM optional supporting IEEE 802.3ah, Dying Gasp, Discovery and Loopback TR-069, including support for TR-181							
Item number DKT	79740	79734	79741	79742	79753	79754	79755	79756
Order No.	84179740	84020734	84179741	84020742	84179753	84179754	84179755	84179756

(1) Data port loop through, adapter SC/APC

(2) Support for VLANs, Q-in-Q, QoS, IGMP, Jumbo Frames and traffic shaping and manipulation

Are you looking for the perfect companion for the DKT Gateways?

You will find matching Fiber Termination Units (FTUs) in our range of passive optical components!

10 Gbps DKT Gateways



84179752
FTTH-10G-2F-3P-CATV,
image with matching FTU

10 Gbps Gateways

The 10 Gbps Gateway series is based upon a sophisticated wirespeed Layer 2 switching-based "System-on-Chip" (SoC) solution. This solution implies that fiber termination and service activation occur as part of the operator's "demarcation point" at the end customer in a FTTH 10 Gbps environment.

Parameter	FTTH-10G-		XGS-PON		XGS-PON with CATV		10G EPON with DPoE	
	1F-3P	2F-3P-CATV	FTTH-XGS-1F-3P	FTTH-XGS-1F-2P	FTTH-XGS-1F-3P-CATV	FTTH-XGS-1F-2P-CATV	FTTH-10G-EPON-1F-3P	FTTH-10G-EPON-1F-2P
10G EPON WAN	-	-	-	-	-	-	Yes	Yes
10 Gbps WAN	Yes	Yes	-	-	-	-	-	-
XGS-PON WAN	-	-	Yes	Yes	Yes	Yes	-	-
1 Gbps LAN	2	2	2	1	2	1	2	1
10 Gbps LAN	1	1	1	1	1	1	1	1
10 Gbps LAN specifications	1x RJ-45, support for 10G BASE-T (also 1G/2,5G/5G), 2 LEDs: Yellow (Speed, 10 Gbps), Green (Link/Activity)							
CATV	-	85 dBµV at -5 dBm, input	-	-	85 dBµV at -5 dBm, input	85 dBµV at -5 dBm, input	-	-
Switch engine ⁽¹⁾	Yes	Yes	Yes	Yes	Yes	Yes	Yes	Yes
WDM filter	-	Optional	-	-	Yes	Yes	-	-
Fiber connector	SC/UPC	SC/UPC & SC/APC	SC/APC	SC/APC	SC/APC	SC/APC	SC/APC (SC/UPC a.A.)	SC/APC (SC/UPC a.A.)
SFP WAN	Yes	Yes	Yes	-	Yes	-	Yes	-
BOSA WAN	-	-	-	Yes	-	Yes	-	Yes
Compatible with click-on FTU	Yes	Yes	Yes	Yes	Yes	Yes	Yes	Yes
TR-069	Yes	Yes	-	-	-	-	-	-
Dimensions (W x H x D) [mm]	88 x 151 x 40							
Operating temperature range [°C]	0 ... 40							
Layer 2 Ethernet	IEEE 802.1Q VLANs incl. Q-in-Q, IEEE 802.1Q tag insertion and stripping, IGMP v2/3 snooping							
Monitoring	OAM optional supporting IEEE 802.3ah, Dying Gasp, Discovery and Loopback							
Item number DKT	79751	79752	79757	79857	79759	79859	79761	79861
Order No.	84179751	84179752	84179757	84179857	84179759	84179859	84179761	84179861

⁽¹⁾ Support for VLANs, Q-in-Q, QoS, IGMP, Jumbo Frames and traffic shaping and manipulation

Are you looking for the perfect companion for the DKT Gateways?

You will find matching Fiber Termination Units (FTUs) in our range of passive optical components!

PASSIVE OPTICAL COMPONENTS

Do you have questions concerning our products or want to place an order?

We look forward to your call!
+49 511 757086

Do you already know, which products you need?
shop.brauntelecom.com

Splice splitter patch outdoor cabinets

WAVEPACE® Fiber cabinets for point to multipoint networks



75700100
Fiber-Cabinet-P2MP-256-SC/APC-Crimp



- Passive ready-to-connect outside plant cabinet for distribution of fiber optic connections via splitters to the subscriber at network level 3
- Robust, application-optimized cabinet made of powder-coated stainless steel
- Smallest cabinet dimensions, only 20 cm depth
- All housing elements can be individually replaced, without any impact to operation
- Mounting frame with hinged patch panel and splice block for easy access to the rear for service and maintenance purpose
- Pre-assembled with 256 SC/APC adapter and pigtails with G.657.A1 fibers in a 12 port horizontal at 22 vertical rows matrix
- Splitter mounting for 24 plug and play splitter modules, 1 splitter module SC/APC 1:16 pre-assembled in the basic configuration
- Parking area for up to 120 SC splitter output cables
- Functional slack storage bag
- Splice module with 90° foldable splice trays, each at max. capacity of 12 fibers for crimp or heat shrink splice protection
- Colored splice trays for different applications (e.g. splitter input connection by feeder cable connection at red tray)
- Integrated protection tube management for pigtail routing from patch to splicing area
- Transparent dust protection caps for identification by means of fiber optic red light source
- Cable feed for cable and protection tubes up to a diameter of 23 mm
- Logical port labeling and color coding, e.g. according to DIN color codes
- Loop function
- RFID tag identification in door handle possible on request

Parameter	Fiber-Cabinet-P2MP-256-SC/APC-Crimp	Fiber-Cabinet-P2MP-256-SC/APC-HS	Fiber-Cabinet-P2MP-256-SC/APC-HS-DIN	Fiber-Cabinet-P2MP-256-LC/APC-Crimp-DIN
Application	Splice/Splicer/Patch	Splice/Splicer/Patch	Splice/Splicer/Patch	Splice/Splicer/Patch
Interface	256 x SC/APC adapters & pigtails		256 x SC/APC adapters & pigtails, pre-assembled acc. to DIN IEC 60304 color code	128 x LC/APC duplex adapters & 256 pigtails, pre-assembled acc. to DIN IEC 60304 color code
Splice capacity	52 splice trays for each 12 x crimp	52 splice trays for each 12 x heat shrink		52 splice trays for each 12 x crimp
Dimensions (H x W x D) [mm]	1.100 x 700 x 200			
Weight [kg]	70			
Protection class	IP55/IK10			
Material	Stainless steel, powder-coated			
Color	Light grey, RAL 7035			
Mounting options	Plinth and duct system			
Cable feed	Bottom			
Number of in- and outlets	Feeder: 6 x up to Ø 23 mm and loop with Ø 23 mm / Access: up to 60 x Ø 13 mm			
Door aperture angle	110°/removable			
Pivot angle mounting frame	45°			
Angle of hinged splice tray	90°			
Lock system	Pivoting lever with lock, RFID tag identification optional			
Order No.	75700100	75700105	75700103	75700102

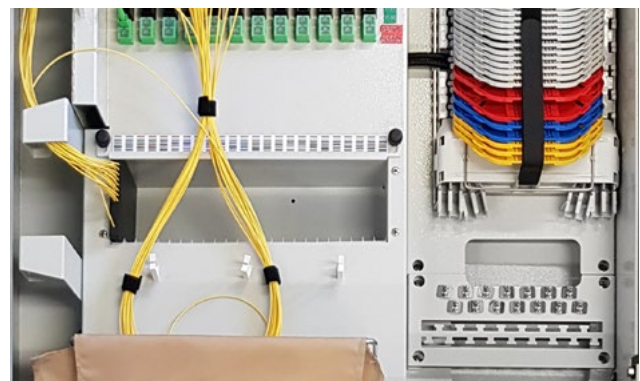
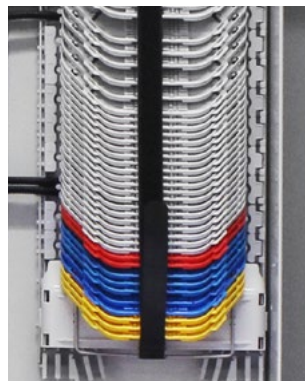
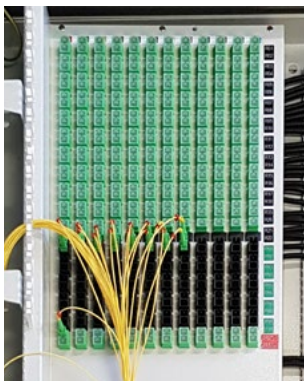

Subject to technical changes!

Setup of the WAVEPACE® Fiber-Cabinet-P2MP with application overview of the individual components

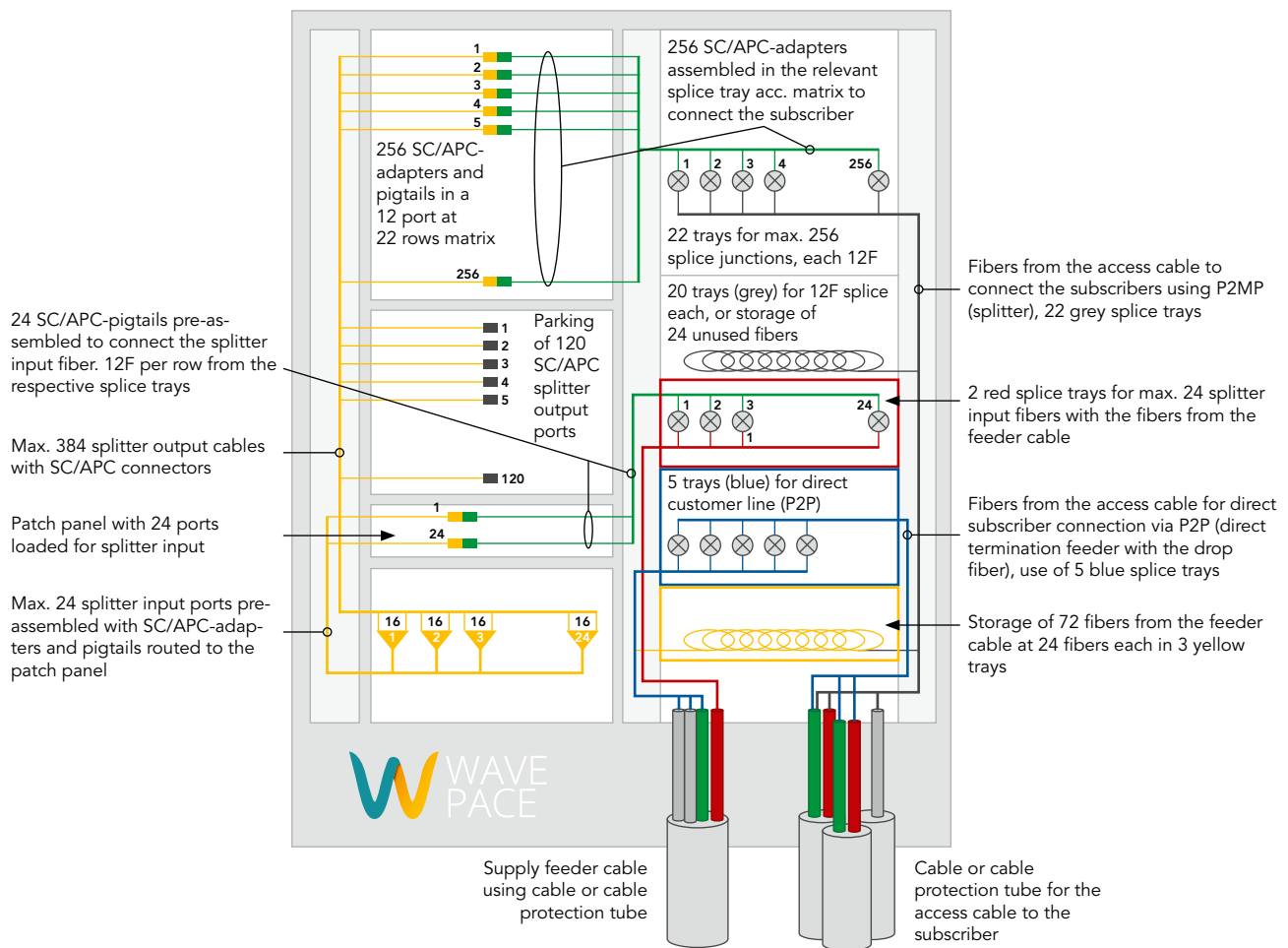

Application example

An appropriate feeder cable is blown in from the PoP to the WAVEPACE® Fiber-Cabinet-P2MP. At the cabinet, the feeder cable gets spliced to splitter input and not used fiber are being stored. Through splicing, the subscribers get connected to the splitter output fiber. The service activation will be carried out by patching the splitter output connector from

the parking area to the corresponding subscriber port. Customers, who need a dedicated line (e.g. for security reasons), will be directly connected with the fibers from the PoP in the blue splice trays, and the service will be provided accordingly.

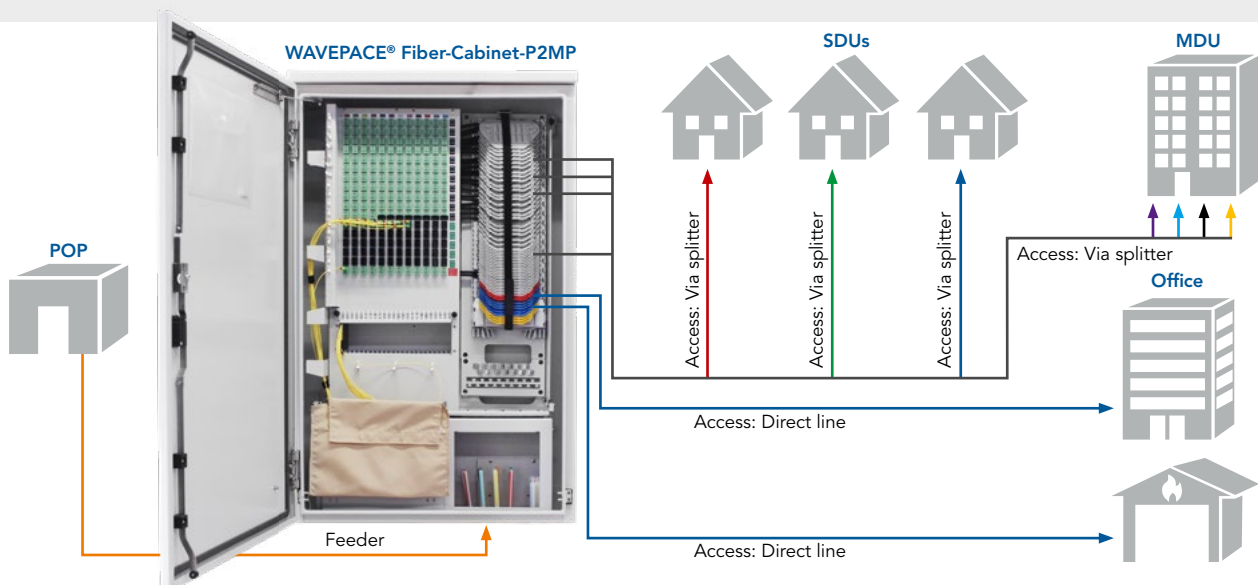

Accessories for the splice splitter patch outdoor cabinet

77700902
Concrete-Base-Fiber-Cabinet



Replacement base plate
available on request



Lightweight concrete base for WAVEPACE® Fiber Cabinet

- Modular lightweight concrete base for quick assembly with removable inspection panel on the front for use with the WAVEPACE® Fiber Cabinet
- The low weight of the individual components facilitates simple assembly
- Smallest housing dimensions, only 20 cm installation depth
- Height from ground level approx. 300 mm
- Designed for a housing with mounting dimensions 635 x 103 mm
- Very space-saving delivery of the dismantled base on one-way pallet

Parameter	Concrete-Plinth-Fiber-Cabinet
Application	Ground plinth for Fiber Cabinet
Total dimensions (H x W x D) [mm]	1.000 x 700 x 200
Dimensions base plate (H x W x D) [mm]	55 x 880 x 350
Weight [kg]	190
Material	Lightweight concrete, concrete quality min. LC 25/28 D1,8
Order No.	77700902

Further accessories

Item	Description	Order No.
Splitter-Module 1:8-SC/APC	PLC-Splitter box, type SC/APC 1:8 for Fiber-Cabinet-P2MP	on request
Splitter-Module 1:16-SC/APC	PLC-Splitter box, type SC/APC 1:16 for Fiber-Cabinet-P2MP	75700110
Splitter-Module 1:16-LC/APC	PLC-Splitter box, type LC/APC 1:16 for Fiber-Cabinet-P2MP	75700112
Splitter-Module 1:32-SC/APC	PLC-Splitter box, type SC/APC 1:32 for Fiber-Cabinet-P2MP, the cabinet housing must be adapted for this splitter module	75700114
Splitter-Module 1:32-LC/APC	PLC-Splitter box, type LC/APC 1:32 for Fiber-Cabinet-P2MP, the cabinet housing must be adapted for this splitter module	75700116
Fiber-Cabinet-Base	Metal base with removable inspection panel	77700905
Base plate	Replacement base plate with foam seal, Access: 6 x Ø 23 mm (+ Loop), outlet: 60 x Ø 13 mm, one base plate is included in the delivery of the WAVEPACE® Fiber-Cabinet-P2MP	on request



WAVEPACE® Fiber-Cabinet-P2MP
with mounted lightweight concrete plinth

ODF systems

WAVEPACE® ODF system



77700900
ODF-System-900,
open



77701200
ODF-System-1200,
closed



- Stable distribution cabinet as a complete unit for termination and distribution of fiber optic technology
- Completely accessible from the front
- Designed for all installation types
- Optimized 19" front and rear mounting rails for installing the WAVEPACE® panel system solutions for free access
- Designed for challenging environmental conditions and needs-oriented growth
- Alignment by use of the freely accessible, adjustable base

- Easy to use, logical cable routing and support
- Guiding element for protective tubes at the inside of the rear wall on each RU
- Cable entry from top and bottom for cables and cable protection tubes
- Connection to external patch cord management systems
- UL listed for UL 2416 for Audio/Video, Information and Communication Technology Equipment Cabinet, Enclosure and Rack Systems
- Compliant with EN 61587-1:2012, Mechanical structures for electronic equipment

Parameter	ODF-System-900	ODF-System-1200
Application	Splice/splitter/patch	Splice/splitter/patch
Dimensions (H x W x D) [mm]	2.200 x 900 x 300	2.200 x 1.200 x 300
Weight [kg]	90	110
Number of doors	2	2
Material	Rack: steel, powder-coated; mounting rail: stainless steel	
Color	Light grey, RAL 7035	
Mounting options	Wall/floor/back to back/row	
Cable feed	Top/bottom	
Door aperture angle	180°	
Environmental conditions	Acc. to IEC 60068-2-1 and 2-2, Cold test: -25 to +70°C, dry heat	
Lock system	Magnetic lock	
Order No.	77700900	77701200



Robust distribution cabinet with innovative mounting solution

The distribution cabinets of the WAVEPACE® ODF-System family are equipped with an access-optimized installation solution for system panels with a free insight and access to the cable routing. Therefore, these ODF systems are the ideal solution for a quick and secure set-up of CO, HE and PoP sites.^{*)} Besides this unique mounting option, the distribution cabinets of course also offer a classic 19" mounting. The split doors protect the wiring of your network, offering optimal access to all working areas with their 180° opening angle for safe and quick handling. The 47 rack units are marked consistently on both mounting profiles with the RU area and the position, thus supporting the panel installation. The height-unit-related patch cable

routing in the right cable routing area ensures a clean and targeted patch cable routing. The management systems ensure long-term and proper cable routing and storage of patch cord slack to increase operational safety.

^{*)} CO: Central Office; HE: Headend; PoP: Point of Presence

Accessories

Item	Description	Order No.
Fiber-Cable-Divider	Cable clamp and divider module for feeder cables Ø 7 – 12 mm using PG-gland up to 192 fibers, division to 8 x protection tube 5/3,5 mm (each 1,75 m long)	10444008



Subject to technical changes!

19" splice panels

WAVEPACE® termination and distribution panel for the ODF system

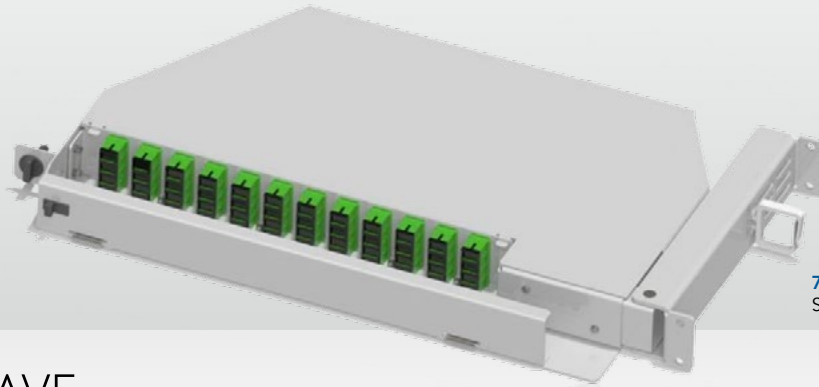

77750004
SP-48-System-Panel-SC/APC



- Torsion-resistant and stable panel construction
- 19" wide panel with unique pivot function
- Pre-assembled with 48 SC/APC or LC/APC ports and pigtails according DIN color code, stored in splice trays, ready for connection
- Patch field with foldable front cover for cable protection and documentation
- Integrated management for fibers and wires
- 4 hinged splice trays at max. capacity of 12 fibers with a 90° hinge angle for good insight and handling
- Cable entry for cables and protective tubes
- Adapter alignment with space in between for secure individual access
- Minimal cable movement and bending radius protection

Parameter	SP-48-System-Panel-SC/APC-Crimp	SP-48-System-Panel-SC/APC-Heat-Shrink	SP-48-System-Panel-LC/APC-Crimp	SP-48-System-Panel-LC/APC-Heat-Shrink	P-48-System-Panel-SC/APC	P-48-System-Panel-LC/APC
Application	Splice/Patch	Splice/Patch	Splice/Patch	Splice/Patch	Patch	Patch
Interface	48 x SC/APC-simplex adapters & 48 pigtails		24 x LC/APC-duplex adapters & 48 pigtails		48 x SC/APC-simplex adapters	24 x LC/APC-duplex adapters
Splice capacity	4 splice trays for 12 x crimp or heat shrink				-	
Dimensions (L x W x D) [mm]	485 x 260 x 44,45 (1 RU)					
Material	Steel, powder-coated					
Color	Light grey, RAL 7035					
Mounting options	System installation, incl. cage nut and screw kit					
Cable feed	Sideways, using U-shaped mounting bracket with protective tube feed					
Pivot angle	90°					
Angle of hinged splice tray	90°					
Performance parameter	IL: 0,25 dB max., RL: 60 dB min.				-	
Fiber type	Single Mode G.657.A1 color coded acc. to DIN (IEC 60304)				-	
Special features	Splitter holder in splice tray				-	
Order No.	77750004	77750002	77750014	77750012	77750007	77750017

Parameter	SP-72-System-Panel-LC/APC-Crimp	SP-72-System-Panel-LC/APC-Heat-Shrink	SP-96-System-Panel-LC/APC-Crimp	SP-96-System-Panel-LC/APC-Heat-Shrink	P-72-System-Panel-LC/APC	P-96-System-Panel-LC/APC
Application	Splice/Patch	Splice/Patch	Splice/Patch	Splice/Patch	Patch	Patch
Interface	18 x LC/APC-quad adapters & 72 pigtails		24 x LC/APC-quad adapters & 96 pigtails		18 x LC/APC-quad adapters	24 x LC/APC-quad adapters
Splice capacity	6 splice trays for 12 x crimp or heat shrink		8 splice trays for 12 x crimp or heat shrink		-	
Dimensions (L x W x D) [mm]	485 x 260 x 44,45 (1 RU)					
Material	Steel, powder-coated					
Color	Light grey, RAL 7035					
Mounting options	System installation, incl. cage nut and screw kit					
Cable feed	Sideways, using U-shaped mounting bracket with protective tube feed					
Pivot angle	90°					
Angle of hinged splice tray	90°					
Performance parameter	IL: 0,25 dB max., RL: 60 dB min.				-	
Fiber type	Single Mode G.657.A1 color coded acc. to DIN (IEC 60304)				-	
Special features	Splitter holder in splice tray				-	
Order No.	77750024	77750022	77750034	77750032	77750027	77750037

Accessories

Item	Description	Order No.
Fiber management panel	19" panel, 3 RU equipped with 3 spools	on request

WAVEPACE® pull-out panel for up to 48 port LC/APC

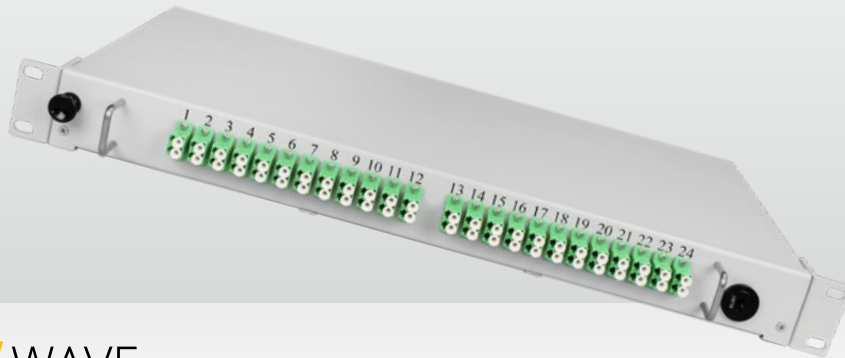

10443957
SP-48-Pull-Panel-LC/APC



- 1 RU pull-out panel for splicing and patching with 19" mounting option
- Robust metal construction with pull-out tray
- Mounting bracket adjustable in depth
- Pre-installed with 24 LC/APC duplex adapters
- Option to include up to 4 splice trays
- Includes separate horizontal cable routing bracket for appropriate installation on the front without disturbing the systems underneath
- Rear cable entry, offset by 30 mm in depth for PG gland and angled feed with hammer head support using cable ties
- Additional support options on the back to secure cables/wires using cable ties
- Installation material and accessories are included in the scope of delivery
- Customer-specific configurations are possible on request

Parameter	SP-48-Pull-Panel-LC/APC	SP-48-Pull-Panel-LC/APC-24-Crimp	SP-48-Pull-Panel-LC/APC-48-Crimp
Application	Splice/patch		
Interface	24 LC/APC duplex adapters pre-installed, bolt for 4 splice cassettes	Ready-to-splice pre-installed with 24 LC/APC duplex adapters and 24 pigtailed according DIN color code, stored in 2 splice trays with crimp splice protection	Ready-to-splice pre-installed with 24 LC/APC duplex adapters and 48 pigtailed according DIN color code, stored in 4 splice trays with crimp splice protection
Capacity	48 port LC/APC, 48 splices		
Material	Metal, powder-coated		
Cable feed	Rear cable entry (left/right offset) for PG 16 and PG 13,5 (each included once in scope of supply), PG gland and angled cable feed with hammer head support for cable ties		
Connector quality	Grade B		
Fiber type	G.657.A1		
Dimensions (L x W x H) [mm]	465 x 240 x 44,45 (1 RU), separate horizontal cable routing bracket: D = 50 mm		
Special features	Key-lock system at right hand side, separate horizontal cable routing bracket		
Color	Light grey, RAL 7035		
Order No.	10443957	10443964	10443965

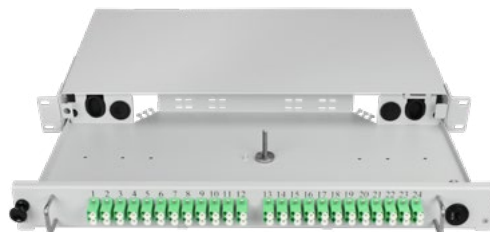

Further splice panels, pre-assembled with splice trays and pigtailed

Parameter	OSP-19-12-SC/APC	OSP-19-24-SC/APC	OSP-19-48-SC/APC	OSP-19-48-SC/APC-2U	OSP-19-72-SC/APC-2U	OSP-19-12-LC/APC	OSP-19-24-LC/APC	OSP-19-48-LC/APC-2U	OSP-19-72-LC/APC-2U
Application	Use in standard 19" racks								
Amount splice cassettes	1	2	4	4	6	1	2	4	6
Amount adapters	12	24	24	48	72	6	12	24	36
Connector type	SC/APC Simplex	SC/APC Simplex	SC/APC Duplex	SC/APC Simplex	SC/APC Simplex	LC/APC Duplex	LC/APC Duplex	LC/APC Duplex	LC/APC Duplex
Amount pigtailed	12	24	48	48	72	12	24	48	72
Dimensions	1 HE	1 HE	1 HE	2 HE	2 HE	1 HE	1 HE	2 HE	2 HE
Material	1,6 mm RAL 7035 light grey								
Order No.	10443950	10443951	10443949	10443952	10443953	10443910	10443911	10443921	10443920

Further splicepanel models are available on request (e.g. FC and E2000)!

19" housings for PLC splitters and multiplexers

with or without pre-installed modules

Sample configuration with a PLC mini splitter and LC/PC connectors

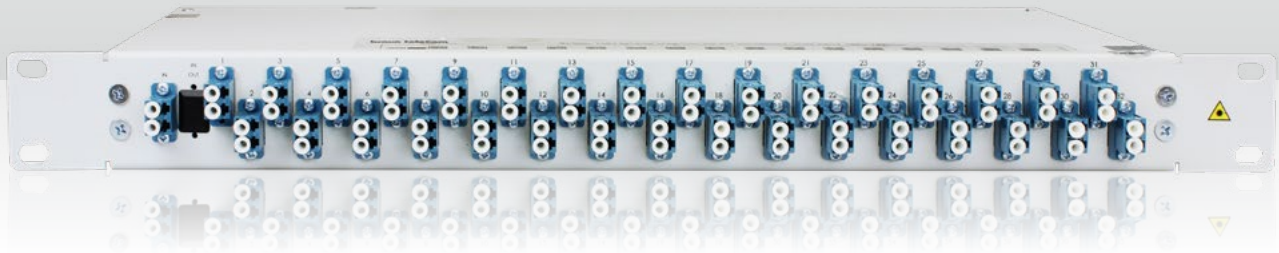

19" housings, pre-installed with PLC mini splitters

Parameter	OSF-19-SC/ APC-16x1/2	OSF-19-SC/ APC-8x1/4	OSF-19-SC/ APC-5x1/8	OSF-19-SC/ APC-1x1/16	OSF-19-SC/ APC-1x1/32	OSF-19-SC/ APC-1x1/64	OSF-19-LC/ APC-1x1/32	OSF-19-LC/ APC-1x1/64
Pre-installed with PLC Mini splitter	16 x 2-way	8 x 4-way	5 x 8-way	1 x 16-way	1 x 32-way	1 x 64-way	1 x 32-way	1 x 64-way
Connector type	SC/APC	SC/APC	SC/APC	SC/APC	SC/APC	SC/APC	LC/APC	LC/APC
Operating wavelength [nm]	1260 ... 1650							
Through loss* [dB max.]	4,2	7,6	10,9	14,0	17,5	21,0	17,5	21,0
Uniformity S/P [dB max.]	0,6	0,6	1,0	1,1	1,5	1,8	1,5	1,8
PDL S/P [dB max.]	0,2	0,2	0,2	0,3	0,3	0,4	0,3	0,4
Directivity [dB min.]	55	55	55	55	55	55	55	55
Return loss [dB min.]	50	50	50	50	50	50	50	50
Maximum optical power [mW]	500	500	500	500	500	500	500	500
Operating temperature range [°C]	-40 ... +85							
Storage temperature range [°C]	-40 ... +85							
Length of the pigtails [m]	1,5 (± 0,1)							
Fiber	Corning SMF-28e XB acc. G657A, 900 µm loose tube							
Dimensions (L x W x H) [mm]	483 x 200 x 44							
Order No.	10443530	10443532	10443534	10443536	10443538	10443540	10443542	10443544

19" housings for PLC mini splitters, empty

Parameter	OSF-19-18-empty	OSF-19-34 empty	OSF-19-16-1x2-empty	OSF-19-8-1x4-empty	OSF-19-5-1x8-empty
PLC splitter	empty				
Port count	max. 2 inputs and 16 outputs	max. 2 inputs and 32 outputs	max. 16 x 1-to-2 SC port structure	max. 8 x 1-to-4 SC port structure	max. 5 x 1-to-8 SC port structure
Dimensions (L x W x H) [mm]	483 x 200 x 44				
Order No.	10443608	10443610	10443614	10443616	10443618

Accessories

Item	Description	Order No.
SP-KA-WE-2x12	Splice tray, white, for 24 crimp splices, 4 splice trays fit into the 1 RU splice box on top of each other	10443443
SP-DL-WE	Cover, white, for splice tray SP-KA-WE-2x12	10443444
Bunny-Clip	Cable bracket, curved, adhesive, e. g. for guiding the pigtails inside the splice box	10443450
Cable-tie-100-2,5	Cable ties/cable straps 100 x 2,5 mm, to be used for up to 25 mm diameter, packaging unit 100 pcs	10443451

19" housings for reception of the CWDM multiplexers and demultiplexers

Parameter	OSF-19-CWDM-8xGPON-SC	OSF-19-CWDM-16xGPON-SC	OSF-19-CWDM-24xGPON-LC	OSF-19-CWDM-32xGPON-LC	OSF-19-CWDM-8xGPON-RFoG-SC	OSF-19-CWDM-MUX-1x9-SC/APC	OSF-19-CWDM-DE-MUX-1x9-SC/APC
Equipment	8 pcs CWDM multiplexer for GPON with RF Overlay	16 pcs CWDM multiplexer for GPON with RF Overlay	24 pcs CWDM multiplexer for GPON with RF Overlay	32 pcs CWDM multiplexer for GPON with RF Overlay	8 pcs with CWDM multiplexer for GPON and RFoG (OLT)	CWDM multiplexer for 9 channels	CWDM demultiplexer for 9 channels
Ports	1 port SC/PC for 1310 ± 40 nm & 1490 ± 10 nm, 1 port SC/APC for 1550 ± 10 nm, 1 COM port SC/APC		1 port LC/PC for 1310 ± 40 nm & 1490 ± 10 nm, 1 port LC/APC for 1550 ± 10 nm, 1 COM port LC/APC		1 port SC/PC for 1310 ± 40 nm & 1490 ± 10 nm, 1 port SC/APC for 1550 ± 10 nm, 1 Pprt SC/APC for 1610 ± 10 nm, 1 COM port SC/APC	1 port for each of the 8 ITU channels 11 – 18 (1471/1491/1511/.../1611 ± 6,5 nm), 1 COM port SC/APC	1 port for 1310 ± 40 nm, 1 port for each of the 8 ITU channels 11 – 18 (1471/1491/1511/.../1611 ± 6,5 nm), 1 COM port SC/APC
Order No.	10450070	10450072	10450074	10450076	10450078	10450080	10450082

PLC mini splitter modules

SFF-type with SC/APC or LC/APC-connectors



10439070
2 x 32 PLC Mini splitter



10439010
1 x 8 PLC Mini splitter

- Based on planar lightwave technology
- Designed as 1 x N splitter with 1 input as well as 2 x N splitter with 2 redundant inputs
- Low through loss, very low PDL
- Excellent port-to-port uniformity

- Very high return loss
- Wide wavelength range
- Highly reliable and stable
- Available in 2 grades: Standard (S) and Premium (P)
- Both grades are qualified with Telcordia standard

1 x N PLC Mini splitter (1 input)

Parameter	1 x 2	1 x 4	1 x 8	1 x 16	1 x 32	1 x 64
Operating wavelength [nm]	1260 ... 1650	1260 ... 1650	1260 ... 1650	1260 ... 1650	1260 ... 1650	1260 ... 1650
Through loss* S/P [dB max.]	4,5/4,2	7,9/7,6	11,3/10,9	14,5/14,0	18,0/17,5	21,5/21,0
Uniformity loss S/P [dB max.]	0,6/0,6	0,8/0,6	1,0/1,0	1,3/1,1	1,5/1,5	1,8/1,8
PDL S/P [dB max.]	0,2/0,2	0,2/0,2	0,3/0,2	0,3/0,3	0,3/0,3	0,4/0,4
Directivity [dB min.]	55	55	55	55	55	55
Return loss [dB min.]	50	50	50	50	50	50
Maximum optical power [mW]	500	500	500	500	500	500
Operating temperature range [°C]	-40 ... +85	-40 ... +85	-40 ... +85	-40 ... +85	-40 ... +85	-40 ... +85
Storage temperature range [°C]	-40 ... +85	-40 ... +85	-40 ... +85	-40 ... +85	-40 ... +85	-40 ... +85
Pigtail length, fiber type [m]	1,5 (± 0,1), Corning SMF-28e XB acc. G657A, 900 µm loose tube					
Dimensions (H x W x L) [mm]	4 x 7 x 60	4 x 7 x 60	4 x 7 x 60	6 x 19 x 100	6 x 19 x 100	6 x 40 x 100
Order No.						
PLSC-(1xN)-P Premium SC/APC	10439100	10439105	10439110	10439115	10439120	10439125
PLLC-(1xN)-P Premium LC/APC	10439300	10439305	10439310	10439315	10439320	10439325

CWDM multiplexers

for 8 ITU channels and 1 channel 1310 ± 40 nm, with SC/APC pigtailed



10450040
CWDM-B-MUX 1x9-SC/APC

- For combining the 8 ITU channels C11-C18 and retrieval of the channel 1310 nm
- 1 port for 1310, each 1 port for the 8 ITU channels C11 – C18 (1471/1491/1511/.../1611 nm), 1 COM-port
- Very low through loss, very low PDL
- Very high isolation, very high directivity
- Very high return loss
- Highly reliable and stable
- Qualified according Telcordia standard

Parameter	CWDM-B-MUX 1x9-SC/APC
Central wavenlengths [nm]	1310, 1471, 1491, 1511, 1531, 1551, 1571, 1591, 1611
Operating wavenlengths [nm]	1310 ± 40 & 1460 – 1620
Channel space [nm]	20
Channel bandwidth [nm]	$\lambda_c \pm 6,5$
Through loss for 1460 – 1620 nm* [dB]	$\leq 3,1$
Through loss for 1310 nm* [dB]	$\leq 0,7$
Channel flatness [dB]	$\leq 0,4$
Channel uniformity [dB]	$\leq 1,0$
Isolation	
Demux-adjacent channels [dB]	≥ 30
Demux-non-adjacent channels [dB]	≥ 40
Mux or reflection channels [dB]	≥ 15
Polarization dependent loss (PDL) [dB]	$\leq 0,15$
Polarization mode dispersion (PDM) [ps]	$\leq 0,1$
Directivity [dB]	≥ 55
Return loss [dB]	≥ 50
Maximum optical power [mW]	≤ 500
Operating temperature range [°C]	0 ... +70
Storage temperature range [°C]	-40 ... +85
Pigtail length, fiber type [m]	1,5 ($\pm 0,1$), Corning SMF-28e, 2 mm fiber
Dimensions [mm]	100 x 80 x 10
Order No.	10450040

* Plus connector loss

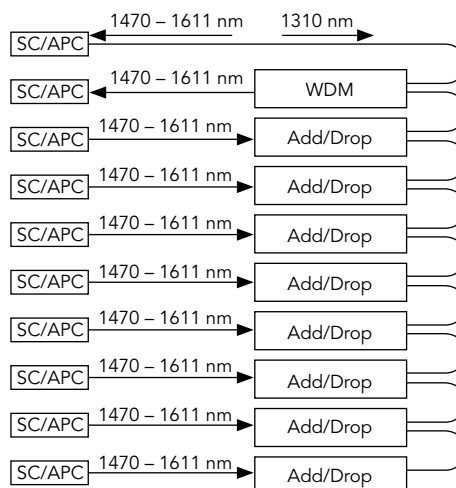

CWDM demultiplexer module for 8 ITU channels and 1 channel 1310 ± 40 nm, with SC/APC pigtailed



10450045
CWDM-B-DEMUX 1x9-SC/APC

- For separation of the 8 ITU channels C11-C18 and insertion of the channel 1310 nm
- 1 port for 1310, each 1 port for the 8 ITU channels C11 – C18 (1471/1491/1511/.../1611 nm), 1 COM-port
- Very low through loss, very low PDL
- Very high isolation, very high directivity
- Very high return loss
- Highly reliable and stable
- Qualified according Telcordia standard

Parameter	CWDM-B-DEMUX 1x9-SC/APC
Central wavelenghts [nm]	1310, 1471, 1491, 1511, 1531, 1551, 1571, 1591, 1611
Operating wavelenghts [nm]	1310 ± 40 & 1460 – 1620
Channel space [nm]	20
Channel bandwidth [nm]	Ac ± 6,5
Through loss for 1460 – 1620 nm* [dB]	≤ 3,5
Through loss for 1310 nm* [dB]	≤ 0,7
Channel flatness [dB]	≤ 0,4
Channel uniformity [dB]	≤ 1,0
Isolation	
Demux-adjacent channels [dB]	≥ 30
Demux-non-adjacent channels [dB]	≥ 40
Mux or reflection channels [dB]	≥ 15
Polarization dependent loss (PDL) [dB]	≤ 0,15
Polarization mode dispersion (PDM) [ps]	≤ 0,1
Directivity [dB]	≥ 55
Return loss [dB]	≥ 50
Maximum optical power [mW]	≤ 500
Operating temperature range [°C]	0 ... +70
Storage temperature range [°C]	-40 ... +85
Pigtail length, fiber type [m]	1,5 (±0,1), Corning SMF-28e, 2 mm fiber
Dimensions [mm]	100 x 80 x 10
Order No.	10450045

* Plus connector loss

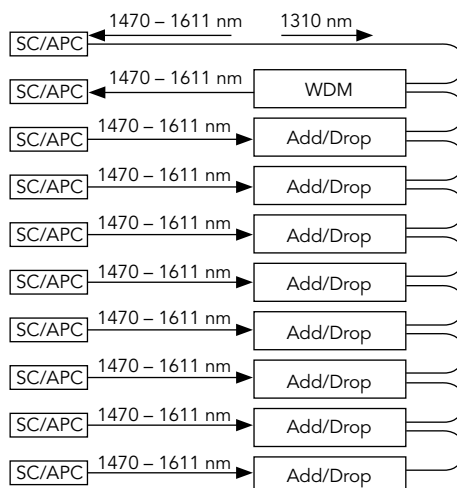

Subject to technical changes!

CWDM multiplexer for GPON with RF Overlay



10450030
CWDM-B-GPON w/ RF-Overlay-
SC/APC, box style

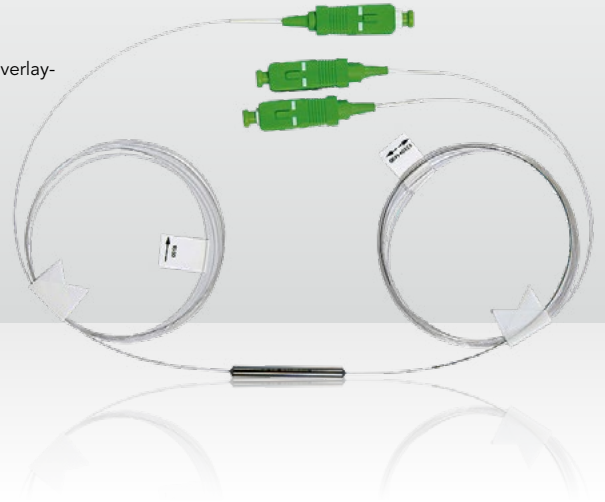

10450035
CWDM-B-GPON w/ RF-Overlay-
SC/APC, tube style

- For combining or separating the 3 wavelengths which are required for a GPON network architecture with RF Overlay (only forward transmission) respectively Active-Ethernet (P2P) with RF Overlay
- Usable as MUX (red signal direction) or DEMUX (blue signal direction) due to the bidirectional design
- 1 Port for 1310 & 1490 nm (GPON),
1 port for 1550 nm (RFoG forward way),
1 COM port
- Very low through loss, very low PDL
- Very high directivity, very high return loss
- Highly reliable and stable
- Qualified according Telcordia standard

Parameter	CWDM-B-GPON w/ RF-Overlay- SC/APC, box style	CWDM-R-GPON w/ RF-Overlay- SC/APC, tube style
Pigtails	alle Anschlüsse SC/APC	alle Anschlüsse SC/APC
Transmitted operating wavelength bandwidth [nm]	1550 ± 10	1550 ± 10
Reflected operating wavelength bandwidth [nm]	1310 ± 40 & 1490 ± 10	1310 ± 40 & 1490 ± 10
Transmitted through loss* [dB]	≤ 0,6	≤ 0,7
Channel flatness [dB]	≤ 0,4	≤ 0,4
Reflected through loss* [dB]	≤ 0,6	≤ 0,4
Isolation		
Transmitted channel [dB]	≥ 30	≥ 25
Reflected channel [dB]	≥ 15	≥ 20
Polarization dependent loss (PDL) [dB]	≤ 0,10	≤ 0,10
Directivity [dB]	≥ 55	≥ 55
Return loss [dB]	≥ 50	≥ 50
Maximum optical power [mW]	≤ 500	≤ 500
Operating temperature range [°C]	0 ... +70	-5 ... +70
Storage temperature range [°C]	-40 ... +85	-40 ... +85
Pigtail length, fiber type [m]	1,5 (±0,1), Corning SMF-28e, 2 mm fiber	1,5 (±0,1), Corning SMF-28e XB
Dimensions [mm]	100 x 80 x 10	Diameter 3,8 x 36
Order No.	10450030	10450035

* Plus connector loss

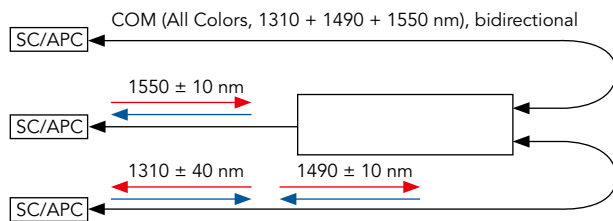

10450030 & 10450035

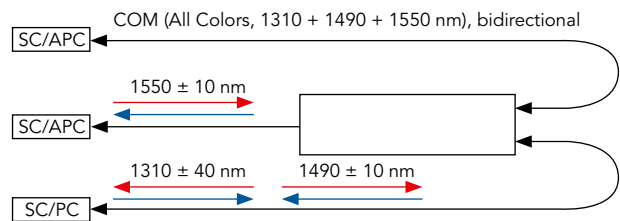

10450036

CWDM multiplexer module for GPON and RFOG (OLT), with SC/APC pigtails



10450020
CWDM-B-GPON + RFOG-OLT-SC/APC,
box style

- For combination or separation of the 4 wavelengths which are required for a combined GPON and RFOG architecture
- Usage in headends and Optical Line Terminals (OLT)
- 1 port for 1310 & 1490 nm (GPON Tx & Rx),
1 port for 1550 nm (RFOG Tx),
1 port for 1610 nm (RFOG Rx),
1 COM port
- Very low through loss, very low PDL
- Very high isolation, very high directivity
- Very high return loss
- Highly reliable and stable
- Qualified according Telcordia standard

Parameter	CWDM-B-GPON + RFOG-OLT-SC/APC, box style
Central wavelenghts [nm]	1310, 1491, 1551, 1611
Operating wavelenghts [nm]	1310 ± 40 & 1460 – 1620
Channel space [nm]	20
Channel bandwidth [nm]	Δc ± 6,5
Transmission through loss* [dB]	≤ 1,2
Channel flatness [dB]	≤ 0,4
Channel uniformity [dB]	≤ 1,0
Isolation	
Demux-adjacent channels [dB]	≥ 30
Demux-non-adjacent channels [dB]	≥ 40
Mux or reflection channels [dB]	≥ 15
Polarization dependent loss (PDL) [dB]	≤ 0,15
Polarization mode dispersion (PDM) [ps]	≤ 0,1
Directivity [dB]	≥ 55
Return loss [dB]	≥ 50
Maximum optical power [mW]	≤ 500
Operating temperature range [°C]	0 ... +70
Storage temperature range [°C]	-40 ... +85
Pigtail length, fiber type [m]	1,5 (± 0,1), Corning SMF-28e, 2 mm fiber
Dimensions [mm]	100 x 80 x 10
Order No.	10450020

* Plus connector loss

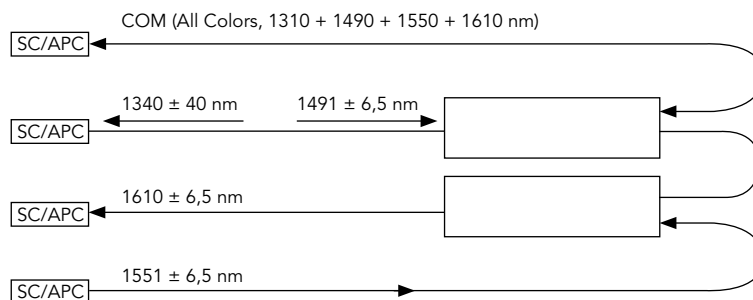

WDM multiplexers with SC/APC pigtails



10450010
WDM-B-1310/1464-1617-SC/
APC, box style

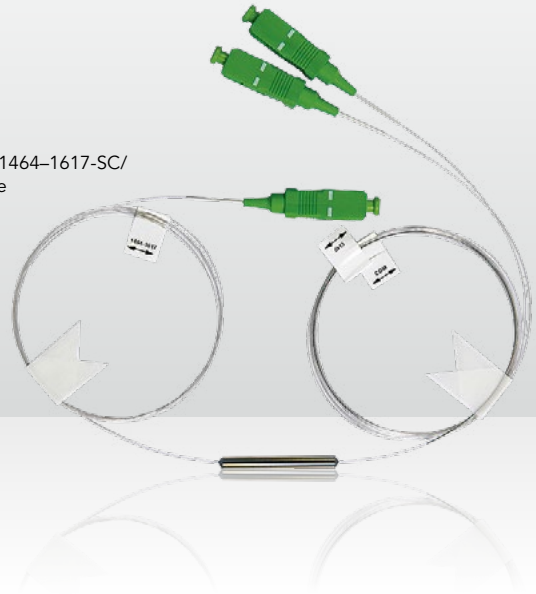

10450015
WDM-R-1310/1464-1617-SC/
APC, tube style

- To combine or separate wavelengths for forward and return path transmission
- Usage as MUX or DEMUX by bidirectional design
- 1 port for 1310 nm,
1 port for 1464 – 1617 nm,
1 COM port
- Very low through loss, very low PDL
- Very high directivity, very high return loss
- Highly reliable and stable
- Qualified according Telcordia standard

Parameter	WDM-B-1310/1464-1617-SC/APC, box style	WDM-R-1310/1464-1617-SC/APC, tube style
Transmitted operating wavelength bandwidth [nm]	1310 ± 40	1464 – 1617
Reflected operating wavelength bandwidth [nm]	1464 – 1617	1310 ± 40
Channel flatness [dB]	≤ 0,4	≤ 0,4
Transmitted through loss* [dB]	≤ 0,6	≤ 0,7
Reflected through loss* [dB]	≤ 0,6	≤ 0,4
Isolation		
Transmitted channel [dB]	≥ 30	≥ 25
Reflected channel [dB]	≥ 15	≥ 20
Polarization dependent loss (PDL) [dB]	≤ 0,10	≤ 0,10
Directivity [dB]	≥ 55	≥ 55
Return loss [dB]	≥ 50	≥ 50
Maximum optical power [mW]	≤ 500	≤ 500
Operating temperature range [°C]	0 ... +70	-5 ... +70
Storage temperature range [°C]	-40 ... +85	-40 ... +85
Pigtail length, fiber type [m]	1,5 (± 0,1), Corning SMF-28e, 2 mm fiber	1,5 (± 0,1), Corning SMF-28e XB acc. G657A, 900 µm loose tube
Dimensions [mm]	100 x 80 x 10	Durchmesser 3,8 x 36
Order No.	10450010	10450015

* Plus connector loss

Configuration box style

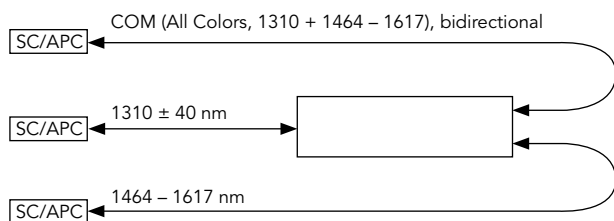

Configuration tube style

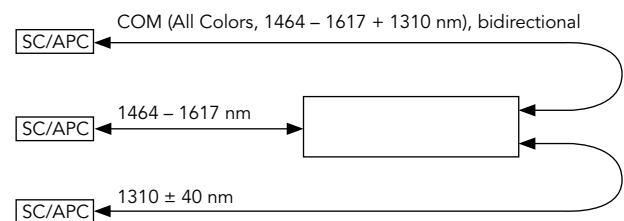

Fiber-optic cable

Blown cable



66000041
A-D(ZN)2Y, 1x4



66000047
A-D(ZN)2Y, 1x12

Blown cables are non-metallic cables with optical fibers, that are mainly installed in confined spaces within the access network. Due to the two-layer cores and the friction-optimized PE sheath, MiniXtend cables are particularly well suited for blowing into mini- or microducts. The fibers within the ducts are colored for better distinctness. MiniXtend are available with Corning SMF 28-e® (ITU-G 652D) or SMF-28® Ultra single-mode fibers with optimized bending.

- Reduced outer diameter
- Installation of customer connections in micro tube/speedpipe systems
- Compact design with reduced weight
- Low investment costs
- Non-metallic cable structure
- No grounding necessary
- Secure transmission properties and low loss
- SMF-28e+® or SMF-28® Ultra according to ITU-T G.652.D

Parameter	A-D(ZN)2Y, 1x4	A-D(ZN)2Y, 1x12	A-D(ZN)2Y-6F-(1X6)-E9U-CT-1.7-SST	A-D(ZN)2Y-12F-(1X12)-E9U-CT-1.7-SST	A-D(ZN)2Y-24F-E9U200-CT1.7
Application	Micro tubes/speedpipes				
Cable type	Central core A-D(ZN)2Y				
Product type	Dielectric				
Longitudinal water tightness (0,1 bar/24 h) [m]	≤ 1				
Crush resistance	1.000 N/10 cm				
Operating temperature range [°C]	-20 – 60				
Fiber category	SMF-28®		SMF-28® Ultra		
Fulfilled standards and norms	TIA/EIA 492-CAAB IEC 60793-2-50 Typ B1.3, ITU-T G.652.D, ISO/IEC 11801 Ed.2.2		ITU-T G.652.D, ITU-T G.657.A1		
Fiber count	4	12	6	12	24
Outer diameter [mm]			2,5		
Packaging unit [m]	2.000		6.000		
Tensile strength (short-term) [N]	80				
Order No.	66000041	66000047	66014006	66014012	66014024

Fixed core installation cable



66000011
J-V(ZN)H-LWL-
Single-Fibre-Drop



66000043
J-V(ZN)H, 1x4



66000049
J-V(ZN)H, 1x12

These fiber optic cables can be used indoors for riser cabling or as distribution cables. The fixed cores enable a simple and direct plug-in field mounting without the use of a distribution adapter. The cables can be routed in cable ducts and manholes inside buildings.

- Metal-free construction
- No potential equalization required
- Easy to install because there is no filling compound
- Fast, direct connector assembly without a dividing adapter

- Suitable for direct assembly of field-installable connectors on the fixed core
- Low cable diameter and bending radius
- Therefore easy installation in confined spaces
- Easily stippable with lengths of approx. 100 mm due to the TB3 fixed core construction
- Silicon-free sheath
- Cable sheath and outer sheath of the basic components (but 900 µm fixed core cables) are free of lacquer-wetting substances
- Flame-retardant LSZH™ / FRNC
- Fiber count: 1, 4 or 12 pcs.

Parameter	J-V(ZN)H-LWL- Single-Fibre-Drop	J-V(ZN)H, 1x4	J-V(ZN)H, 1x12
Application	Indoor		
Cable type	Fixed core		
Product type	Dielectric		
Longitudinal water tightness (0,1 bar/24 h) [m]	≤ 0,1		
Fier class	LSZH™/FRNC		
Fiber category	SMF-28® Ultra Faser 0,9 mm; ITU-T G.652.D and ITU-T G.657.A1		
Coding acc. to DIN VDE 0888-100-1 (EN 60794-1-1)	J-V(ZN)H		
Former coding acc. to DIN VDE 0888-3	J-VH		
Fire behaviour	Cca, s1a, d1, a1		
Outer diameter [mm]	2,4	4,2	
Fiber count	1	4	12
Packaging unit [m]	2.000		
Tensile strength at installation [N]	200	600	
Order No.	66000011	66000043	66000049

The perfect addition: WAVEPACE® connectors for field termination

- SC/APC connector with short boot for field termination at 900 µm buffer and cable diameters up to 3 mm
- V-groove and matching gel
- Reusable in case of poor performance values
- Temperature range: -25°C – +70°C
- Packaging unit 60 pcs
- Incl. cleaving tool

Item	Description	Order No.
SC/APC-connector-field-termination	SC/APC connector, IL: typical ≤ 0,3 dB (max. ≤ 0,6 dB), RL: ≥ 55 dB media	10444050
LC/APC-connector-field-termination	LC/APC connector IL: typical ≤ 0,3 dB (max. ≤ 0,5 dB), RL: ≥ 55 dB media	10444051



10444050
SC/APC-connector-
field-termination

MiniXtend® universal cable

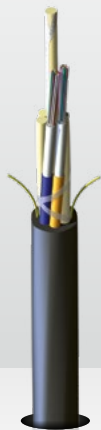

66000024
U-DQ(ZN)H-2x12-
E9/125-SMF-28-Ultra



66000050
U-DQ(ZN)H-4x12-
E9/125-SMF-28-Ultra

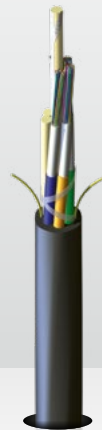

66000096
U-DQ(ZN)H-4x24-
E9/125-SMF-28-Ultra

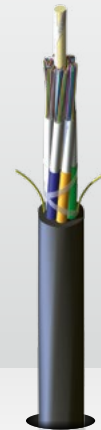

66000144
U-DQ(ZN)H-6x24-
E9/125-SMF-28-Ultra

- Indoor/outdoor universal cables, typically used when limited space is available
- With the dual layer tube design and low friction sheath MiniXtend cables are optimised for blowing and best used in mini or micro ducts
- The buffer tubes and fiber in each tube are colour-coded to Telcordia-Bellcore for quick and easy identification
- Designed with increased resistance against moisture or chemicals
- Additional flame retardant features enable indoor/outdoor deployments along ducts or pipelines
- Reduced outer cable diameter for high fibre density in microduct systems
- All-dielectric cable construction, no need for grounding or bonding
- All MiniXtend® cables are RoHS compliant

Parameter	Wavelength [nm]	U-DQ(ZN)H-2x12- E9/125-SMF-28-Ultra	U-DQ(ZN)H-4x12- E9/125-SMF-28-Ultra	U-DQ(ZN)H-4x24- E9/125-SMF-28-Ultra	U-DQ(ZN)H-6x24- E9/125-SMF-28-Ultra
Application		Blowing installation in miniduct systems			
Cable type		Loose Tube			
Product type		Dielectric			
Flame rating		LSZH™/FRNC			
Coding according to EN 60794-1-1 (DIN VDE 0888-100-1)		U-DQ(ZN)H			
Reaction to fire		Eca			
Fiber Category		SMF-28® Ultra 200 Optical Fiber			
Installation temperature range [°C]		-5 – 50			
Operation/storage temperature range [°C]		-40 – 70			
Central element		Dielectric with swellable element			
Fiber count		24	48	96	144
Fibers per tube		12	12	24	24
Number of tube positions		6	6	6	6
Number of active tubes		2	4	4	6
Buffer tube colour		Blue, orange	Blue, orange, green, brown	Blue, orange, green, brown	Blue, orange, green, brown, gray, white
Buffer tube diameter [mm]		1,7	1,7	1,7	1,7
Number of filling elements		4	2	2	-
Number of ripcords		2	2	2	2
Outer sheath material		Flame-retardant, non-corrosive/low-smoke, zero-halogen (FRNC/LSZH) material			
Outer sheath colour		Black	Black	Black	Black
Outer sheath nominal thickness [mm]		1,2	1,2	1,2	1,2
Nominal outer diameter [mm]		7,8	7,8	7,8	7,8
Weight [kg/km]		51,74	57,3	60,36	67,48
Min. bend radius installation/operation [mm]		78/117	78/117	78/117	78/117
Max. tensile strength, short-term [N]		1.000	1.000	1.000	1.000
Crush resistance (reversible) [N/10 cm]		1.000	1.000	1.000	1.000
Fire Load [MJ/m]		1.475	1.413	1.413	1.357
Fiber name		SMF-28® Ultra 242 Optical Fiber		SMF-28® Ultra 200 Optical Fiber	
Mode field diameter [µm]	1310	9,2	9,2	9,2	9,2
Fiber code		Z	Z	Z	Z
Coating/cladding diameter [µm]		242/125	242/125	200/125	200/125
Maximum/typical attenuation [dB/km]	1310	0,34/0,32	0,34/0,32	0,34/0,32	0,34/0,32
	1383	0,34/0,32	0,34/0,32	0,34/0,32	0,34/0,32
	1550	0,20/0,18	0,20/0,18	0,20/0,18	0,20/0,18
Serial 1 gigabit ethernet [m]		5.000/-	5.000/-	5.000/-	5.000/-
Serial 10 gigabit ethernet [m]		10.000/40.000	10.000/40.000	10.000/40.000	10.000/40.000
Cable cutoff wavelength [nm]		1260	1260	1260	1260
Dispersion [ps/(nm*km)]	1285 – 1300	≤ 3,5	≤ 3,5	≤ 3,5	≤ 3,5
	1550	≤ 18	≤ 18	≤ 18	≤ 18
PMD Link Design Value [ps/√km]		≤ 0,04	≤ 0,04	≤ 0,04	≤ 0,04
PMD maximum individual fiber [ps/√km]		≤ 0,1	≤ 0,1	≤ 0,1	≤ 0,1
Fiber compliance		ITU-T G.652.D and ITU-T G.657.A1			
Order No.		66000024	66000050	66000096	66000144

MiniXtend® blown cable



66012096
A-DQ(ZN)2Y-8x12-
E9G.657.A1-LT1.4-FAB



66012144
A-DQ(ZN)2Y-12x12-
E9G.657.A1-LT1.4-FAB

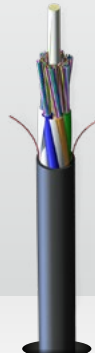

66014144
A-DQ(ZN)2Y-144F-
E9U200-W/FAB



66014192
A-DQ(ZN)2Y-192F-
E9U200-W/FAB

- Cable for installation in micro tubes
- Very good installation properties due to optimized cable stiffness and low-friction sheath
- Good mechanical properties
- A metal-free cable without grounding or potential problems
- The innovative FastAccess® technology simplifies cable stripping without the use of ripcords and special tools
- The Corning E9U200/125 SMF 28® ULTRA single-mode fiber used is an ITU-T G652.D fiber with Corning's "low-loss" and bending-optimization technology. This full-spectrum fiber exceeds the bending requirement of ITU-T G657.A1 and is fully compatible with standard single mode fibers, such as Corning SMF28e+®
- Fiber and core colors according to VDE
- Cable construction according to Corning standard

Parameter	Wavelength [nm]	A-DQ(ZN)2Y-6x12-E9U200-LT1.1-FAB	A-DQ(ZN)2Y-8x12-E9G.657.A1-LT1.4-FAB	A-DQ(ZN)2Y-12x12-E9G.657.A1-LT1.4-FAB	A-DQ(ZN)2Y-144F-E9U200-W/FAB	A-DQ(ZN)2Y-192F-E9U200-W/FAB	A-DQ(ZN)2Y-288F-E9U200-W/FAB
Application		Micro tubes					
Cable type		Minibündelmikrokabel					
Product type		Dielectric					
Fiber category		SMF-28® Ultra 200 optical fibers					
Installation temperature range [°C]		-5 – +40					
Operation/storage temperature range [°C]		-40 – +70 / -30 – +70					
Central element		Dielectric with swellable element					
Fiber count		72	96	144	144	192	288
Fibers per tube		12	12	12	24	24	24
Number of tube positions		6	8	12	6	8	12
Number of filling elements		0	0	0	0	0	0
Outer sheath material		High-density polyethylene (HDPE)					
Outer sheath colour		black					
Nominal outer diameter [mm]		4,4 ± 0,3	6,3 ± 0,3	8,1 ± 0,3	6,3 ± 0,3	7,5 ± 0,3	9,7 ± 0,3
Weight [kg/km]		23	35	56	37	55	87
Min. bend radius installation/operation [mm]		88 / 66	15xD / 10xD				
Max. tensile strength, short-term [N]		350	1.000				
Crush resistance (reversible) [N/10 cm]		1.000					
Fiber name		E9/125 SMF 28® ULTRA					
Mode field diameter [µm]	1310	9,2	9,2 ± 0,4				
Cladding diameter [µm]		125	125,0 ± 0,7				
Coating diameter [µm]		200	200 ± 5				
Attenuation [dB/km]	1310	≤ 0,34					
	1383	≤ 0,34					
	1550	≤ 0,20					
Cable cutoff wavelength [nm]		≤ 1260					
Dispersion [ps/(nm*km)]	1285 – 1300	≤ 3,5					
	1550	≤ 18					
PMD Link Design Value [ps/√km]		≤ 0,04	≤ 0,06				
PMD maximum individual fiber [ps/√km]		≤ 0,1	≤ 0,2				
Fiber compliance		ITU-T G.652.D and ITU-T G.657.A1					
Order No.		66000072	66012096	66012144	66014144	66014192	66014288

MiniFlex cable



66000202
Miniflex-2F-2,2



66000302
Miniflex-2F-3,0

The MiniFlex Euroclass cable is a tough and lightweight optical fiber loose tube cable, available with up to 12 optical fibers. At just 2,2 or 3,0 mm outer diameter MiniFlex is a rugged, ultra-flexible drop cable solution for pushing and pulling inside raceways or for fixing directly to building surfaces. By virtue of the MiniFlex grooving technology this ruggedize lightweight fiber cable is ultra flexible whilst resisting the urge to kink like regular fiber cables. No specialist installation tools are required to push/pull MiniFlex through FTtx microducts. When combined with low-friction microducts, the cable can be pushed by hand in long routes.

- UV stabilized
- Ultra tough
- Very lightweight
- Small diameter (3 mm for up to 12 fibers)
- High crush resistance
- Best-is-class push/pull and blowability
- Ultra-flexible, small bend radius for compact slack fiber storage
- Small and unobtrusive enough for surface mount applications
- Tough enough for clipping, tacking and gluing

Parameter	MiniFlex-1F-2,2	MiniFlex-2F-2,2	MiniFlex-4F-2,2	MiniFlex-1F-3,0	MiniFlex-2F-3,0	MiniFlex-4F-3,0	MiniFlex-6F-3,0	MiniFlex-8F-3,0	MiniFlex-12F-3,0	
Application	Indoor and outdoor									
Fiber category	ITU-T G.657 A1									
Product type	Dielectric									
Fiber coating [µm]	250									
EN CPR Rating	Eca	Eca	Eca	Cca	Cca	Cca	Cca	Cca	Cca	
Outer diameter [mm]	2,2	2,2	2,2	3,0	3,0	3,0	3,0	3,0	3,0	
Fiber count	1	2	4	1	2	4	6	8	12	
Max. attenuation	1310 nm				≤ 0,40					
[dB/km]	1550 nm				≤ 0,35					
Min. bending radius, attenuation	10 curves, 15 mm				0,20					
at 1550 nm [dB]	1 curve, 10 mm				0,50					
Tensile strength [N]	100									
Operating temperature range [°C]	-40 – +70									
Packaging unit [m]	2.000									
Order No.	66000201	66000202	66000204	66000301	66000302	66000304	66000306	66000308	66000312	

Fiber-optic indoor cable



66000038
COR1821-4-Fiber-
4xG657A2



66000045
FR-Micro-Cable-
4F-Cca

- These fiber optic cables (COR1821 from ACOME and FR-Micro-Cable-4F from CORNING) have been specially developed for in-house subscriber connection in FTTH networks
- The cables are suitable for cabling in the building and can be e.g. blown or pulled into micro tubes, cable ducts, intermediate floors and hollow walls
- Halogen-free, flame-retardant jacket (LSOH)
- UV resistant
- Lightweight cables with small outer diameter
- Suitable for blowing into distances up to 150 m

Parameter	COR1821-4-Fiber-4xG657A2	FR-Micro-Cable-4F-Cca
Application		Indoor
Fiber count	4	4
Fiber type	Singlemode G.657.A2	Singlemode ClearCurve® LBL
Product type		Dielectric
Outer diameter [mm]	2,65	2,4
Outer jacket thickness [mm]	0,5	0,58
Outer jacket color	Ivory	White
Outer jacket material	Halogen free, flame retardant (LSOH), UV resistant	
Tensile strength [N]	250	150
Crush resistance [N/cm]	200	50
Minimal bending radius [mm]	10	40
Weight [kg/km]	6,50	7
Reaction to fire	Dca-s2,d2,a2	Cca, s1, d1, a1
Flame propagation test	IEC 60332-1	IEC 60332-1-2 (single cable) and IEC 60332-3-24 (bunch of cables)
Operational temperature range [°C]	-5 – +70	-10 – +60
Max. distance for blowing in [m]	150	150
Order No.	66000038	66000045

Smooth Fiber Units



66000060
ACE-TKF-SFU-6xSM-G.657A1

- TKF's Smooth Fiber Units (SFU) consist of a bundle of fibers encapsulated by a dry acrylic layer
- Protected by a smooth, lightly ribbed polyethylene outer jacket
- For use in the access network
- Suitable for blowing into micro tubes of 3,5 mm or 4,0 mm inner diameter
- Halogen free acc. to EN 60754-1/2

Parameter	ACE-TKF-SFU-4xSM-G.657A1	ACE-TKF-SFU-6xSM-G.657A1	ACE-TKF-SFU-12xSM-G.657A1
Application	Indoor & outdoor		
Fiber count	4	6	12
Fiber type	Singlemode 9/125, fiber ITU-T G.657.A1		
Core type	Central loose tube		
Product type	Dielectric		
Outer diameter [mm]	1,4	1,4	1,7
Outer jacket thickness [mm]	0,15		
Outer jacket color	Yellow		
Outer jacket material	Polyethylene (PE)		
Tensile strength [N]	20		
Crush resistance [N/cm]	100		
Minimal bending radius [mm]	40		
Weight [kg/km]	2		
Reaction to fire	Fca		
Operating temperature range Ta1 – Tb1 [°C]	-30 – +70		
Operating temperature range Ta2 – Tb2 [°C]	-40 – +70		
Order No.	66000039	66000060	66000062

Matching accessories: Fiber Beads

- For Smooth Fiber Units (SFUs) with 2 or 4 fibers
- Applied to the fiber optic cable, these end caps improve blow-in performance and protect the cable
- The fiber bead compensates for unevenness, such as connector transitions, during the blowing process and the cable does not get stuck
- Mounting with crimp tool
- Packing unit 25 pcs
- Material: Brass



Order No. 43022718

Speedpipes, micro tubes and accessories

Special solutions for indoor or outdoor applications



42575355
LSOH-MDD-1824/
X5017A

42575360
LSOH-MDD-1824/
H0260A

42575361
LSOH-MDD-1824/
H0261A

Parameter	LSOH-MDD-1824/X5017A	LSOH-MDD-1824/H0260A	LSOH-MDD-1824/H0261A
Application	Indoor		
Incl. needle/string for easy insertion of the fiber optic cable	Yes	No	Yes
Standard packaging [m]	500		
Inner diameter [mm]	3,5	4	4
Outer diameter [mm]	5	7	7
Weight [kg/km]	17,0	40,0	41,0
Operating temperature range [°C]	-15 – +70	-40 – +70	-40 – +70
Flame retardant according to	EN 50290-2-27		
Color	Ivory		
Minimum bending radius [mm]	20	15	15
UV resistant	Yes		
Producer / brand	ACOME		
Order No.	42575355	42575360	42575361

Parameter	sp-i-7x1,5	sp-i-10x2,0	sp-i-14x2,0	Speedpipe-ground-7x1,5	Speedpipe-ground-10x2,0	Speedpipe-ground-14x2,0
Application	Indoor			Outdoor, for direct burial		
Standard packaging on drum [m]	1.250	2.500	1.500	1.250	2.500	1.500
Inner diameter [mm]	4	6	10	4	6	10
Outer diameter [mm]	7	10	14	7	10	14
Material	Polyethylene PE – flame retardant, halogen free & low smoke			Polyethylene PE-HD – regenerate- and recycle-free		
Weight [kg/km]	30	53	76	30	50	74
Operating temperature, outdoor [°C]	not specified			-40 – +70		
Special features	Halogen free acc. to DIN EN 60684-2 < 0,02 %			3 years UV resistant according to DIN EN ISO 4892-1 (Southern European climate)		
Reaction to fire acc. to DIN EN 13501-1	D s3 d2			E		
Color	White			Orange	Pink	Orange
Minimum bending radius [mm]	70	100	140	70 (guided 65)	100 (guided 65)	140 (guided 100)
Producer / brand	Gabocom					
Order No.	42601686	42603525	42600014	42602223	42601340	42600214

Indoor speedpipe accessories



Indoor connectors

- For tension-proof and pressure-tight connection of indoor speedpipes with identical diameters
- Metal-free and transparent base body
- Suitable for injection pressures up to 15 bar
- Flame retardant according to DIN EN 61386-22
- Not suitable for direct burial

Parameter	VF-5	FDF-5	DSM-7-indoor	DSM-10-indoor	DSM-14-indoor
For outer tube diameter [mm]	5	5	7	10	14
Packing quantity [pcs]	10	10	50	50	25
Gas stop	No	Yes	No	No	No
Special features	For e.g. Hydra cable; Stainless steel clamping teeth		-		
Producer / brand	Emtelle		Gabocom		
Order No.	43022707	43022708	42601220	42601221	42600102

Indoor end caps

- For permanent, tension-proof and pressure-tight sealing of unoccupied indoor speedpipes
- Metal-free and transparent base body
- Suitable for injection pressures up to 15 bar
- Flame retardant according to DIN EN 61386-22
- Not suitable for direct burial

Parameter	ESKF-5	EGKF-5	ES-7-indoor	ES-10-indoor	ES-14-indoor
For outer tube diameter [mm]	5	5	7	10	14
Packing quantity [pcs]	250	10	50	50	50
Gas stop	No	Yes	No	No	No
Special features	For e.g. Hydra cable; Stainless steel clamping teeth		-		
Producer / brand	Emtelle		Gabocom		
Order No.	43022705	43022706	42601694	42601695	42600101

Indoor sealing element „EZA-t-14/6,5-8,0“

- Divisible and reusable sealing element for sealing unoccupied and occupied indoor speedpipes
- Tight against gas and water up to 10 bar
- Suitable for speedpipes with outer diameter 14 mm
- Sealing range cable outer diameter 6,5 – 8,0 mm
- Packing unit 40 pcs.

Order No. 42600103

Indoor divisible connectors/closures for blowing-in

- Halogen-free, flame retardant, tensile strong and divisible
- For gas- and water-tight connection of occupied speedpipes up to 0,5 bar
- Installation without special tools
- Fire behavior of hard components classified according to DIN EN 13501-1
- Designed for operating temperatures from 0 – 50°C (storage and installation)

Item	Tube diameter [mm]	Packing quantity [pcs]	Order No.
EBM-7-indoor	7	12	42601748
EBM-10-indoor	10	12	42601749
EBM-14-indoor	14	12	42600104

Outdoor speedpipe accessories



42465515
Miniduct-seal-10/2,9,
divisible construction



42465515
Miniduct-seal-10/2,9,
installed

Outdoor connectors

- Connector for pressure-tight connection of speedpipes with the same or different outer diameter
- Quick and easy assembly, easy disassembly with release ring
- Particularly resistant to external influences and contamination with direct burial

Parameter	VF-4	VF-7	RVF-4-7	DSM-7	DSM-10	DSM-14	DSM-16	RSM-16/14	RSM-14/12	RSM-10/7	RSM-7/5
Outer diameter, tube 1 [mm]	4	7	7	7	10	14	16	16	14	10	7
Outer diameter, tube 2 [mm]	4	7	4	7	10	14	16	14	12	7	5
Packing quantity [pcs]	10	10	10	50	50	25	25	25	25	25	25
Operating pressure [bar]	16			15							
Producer / brand	Emtelle			Gabocom							
Order No.	43022650	43022712	43022651	42602397	42602398	42600302	42602276	42602281	42602280	42602278	42601456

Outdoor end caps

- Gas- and watertight sealing of speedpipes up to 0,5 bar
- High tensile strength with easy assembly
- Removal possible with retaining ring
- Suitable for buried installation

Item	Tube diameter [mm]	Packing quantity [pcs]	Order No.
ES-7	7	50	42602400
ES-10	10	50	42602401
ES-14	14	25	42600301

Outdoor fiber feed through

- Fittings to create a water- and gas-tight connection and seal between the speedpipe and the cable
- Subsequent release is possible by pressing the collet chuck
- With gas stop – sealing against gas (permanently): 0,3 bar

Item	Tube diameter [mm]	Cable diameter [mm]	Qty. [pcs]	Order No.
FDf-7/1,0-1,6	7	1,0 – 1,6	10	43022713
FDf-7/1,8-2,4	7	1,8 – 2,4	10	43022714
FDf-7/2,5-3,0	7	2,5 – 3,0	10	43022715

Outdoor sealing elements

- Split design, therefore possibility of subsequent installation
- Slim design for use in distribution cabinets, closed or wall boxes
- Gas and water tight up to 0,5 bar

Item	Tube diameter [mm]	Cable diameter [mm]	Qty. [pcs]	Order No.
Miniduct-seal-7/0,9	7	0,8 – 1,1	100	42463557
Miniduct-seal-7/1,25	7	1,2 – 1,5	100	42465572
Miniduct-seal-7/1,6	7	1,8 – 1,8	100	42465573
Miniduct-seal-7/2,1	7	1,9 – 2,2	100	42465575
Miniduct-seal-7/2,5	7	2,3 – 3,0	100	42465574
Miniduct-seal-10/0,9	10	0,8 – 1,1	100	42465510
Miniduct-seal-10/1,25	10	1,2 – 1,5	100	42465511
Miniduct-seal-10/1,6	10	1,6 – 1,9	100	42465512
Miniduct-seal-10/2,1	10	2,0 – 2,3	100	42465513
Miniduct-seal-10/2,5	10	2,4 – 2,7	100	42465514
Miniduct-seal-10/2,9	10	2,8 – 3,1	100	42465515
Miniduct-seal-10/3,3	10	3,2 – 3,6	100	42465516
Miniduct-seal-10/3,8	10	3,7 – 4,0	100	42465517
EZA-t-14/6,5-8,0	14	6,5 – 8,0	40	42600303

Outdoor divisible connectors/closures for blowing-in

- For permanent connection of occupied speedpipes up to 0,5 bar, gas- and water-tight for 30 minutes up to 10 bar
- Installation without special tools

Item	Tube diameter [mm]	Packing quantity [pcs]	Order No.
EBM-7	7	12	42610753
EBM-10	10	12	42610786
EBM-14	14	12	42600304

House infeeds

Home entries for FTTH connections

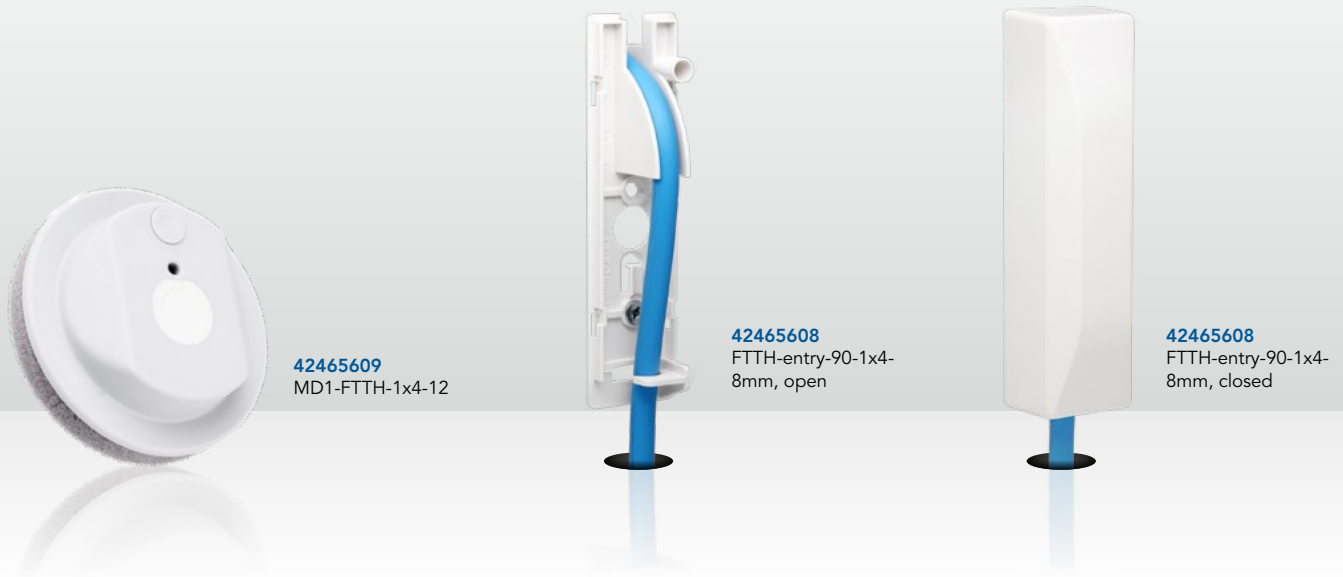

42465609
MD1-FTTH-1x4-12

42465608
FTTH-entry-90-1x4-8mm, open

42465608
FTTH-entry-90-1x4-8mm, closed

FTTH single wall feedthrough

- Gas and watertight house entry for speedpipes and cables up to 2 bar
- Quick and easy installation without special tools
- No complex core drilling necessary
- Also suitable for angled feedthroughs
- For all common types of masonry with waterproofing according to DIN 18533 - Water penetration class W1-E and W2-E

Parameter	MD1-FttH-1x4-12	MD1-FttH-1x14-20
Diameter speedpipe/cable [mm]	4 – 12	14 – 20
Diameter drilling [mm]	16 – 20	32 – 40
Dimensions closure cap / inner diabeler / height [mm]	106 / 72 / 24	
Start of expansion [seconds]	20	
End of expansion [minutes]	2	
Curing time [minutes]	5	
Pressure load capacity [N/cm ²]	> 60	
Density [kg/m ³]	> 50	
Gas tight [bar]	≥ 2	
Pull-out resistance tube/cable [N]	> 400	
Order No.	42465609	42465610

90° FTTH infeeds

- Above-ground house entry as a visual cover for the tube entry into the building
- Integrated bending radius for safe deflection of speedpipes and cables
- Genügend Raum, um bspw. Gasblocker unterzubringen
- Sealing compound type MD+ included in the scope of delivery
- Material PC/ASA, flame retardant
- UV and weather resistant, suitable for outdoor use

Parameter	FTTH-entry-90-1x4-8mm	FTTH-entry-90-1x10-12/2x7mm
Diameter speedpipe/cable [mm]	4 – 8	10 – 12
Diameter drilling [mm]	10 – 25	22 – 32
Dimensions L x W x H [mm]	120 x 45 x 28	160 x 40 x 40
Density of the sealing compound [g/cm ³]	1,2	
Pull-out resistance tube/cable, sealing compound [N]	≥ 1.000	
Hardening of the sealant [mm/24 hours]	3	
Scope of delivery	25 infeeds & 1 cartridge sealing compound 310 ml	6 infeeds & 1 cartridge sealing compound 310 ml
Order No.	42465608	42465611

Matching accessory: 90° speedpipe branching aids

- For guided branching of speedpipes at an angle of 90°
- Can be optionally equipped with a marking ball to facilitate later location of the branch
- Material: Acrylnitrile-Butadien-Styrole ABS

Item	Form	Bending radius [mm]	Dimensions L x W x H [mm]	Packing quantity [pcs]	Order No.
LBS	L form	175	282 x 282 x 30	12	42602330
TBS	T form	175	495 x 300 x 30	12	42602423

Patch cords

WAVEPACE® simplex patch cords with SM G.657.A2 fiber

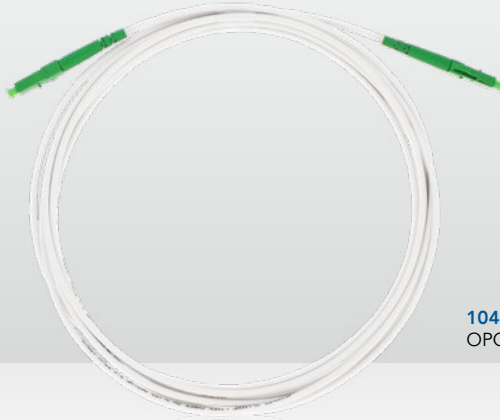

10448403
OPC-2,0-3-LC/APC-LC/APC



Parameter	OPC-2,0-x-SC/APC-SC/APC	OPC-2,0-x-LC/APC-SC/APC	OPC-2,0-x-LC/APC-LC/APC	OPC-2,8-x-SC/APC-SC/APC	OPC-2,8-x-LC/APC-SC/APC	OPC-2,8-x-LC/APC-LC/APC
Patch cord type	Simplex LSZH fiber optic patch cord					
Cable color	white			yellow		
Cable diameter [mm]	2,0			2,8		
Max. tensile strength, short-term [N]	150			240		
Min. bending radius, static [mm]	7,5					
Max. crush resistance per 100 mm, short-term [N]	1.000					
Flame retardancy rating	CPR Dca					
Insertion loss [dB]	≤ 0,25					
Return loss [dB]	> 65 (plunged)					
Fiber type	SM G.657.A2					
Operation, installation and storage temperature range [°C]	-20 – 70					
Compliances	RoHS 3 (2015/863), REACH and UL94 V-0					
Connectors	2 x SC/APC, 8°, Grade B	1 x LC/APC, 1 x SC/APC, 8°, Grade B	2 x LC/APC, 8°, Grade B	2 x SC/APC, 8°, Grade B	1 x LC/APC, 1 x SC/APC, 8°, Grade B	2 x LC/APC, 8°, Grade B
Order No. 1,0 m	10448001	10448201	10448401	10448101	10448301	10448501
Order No. 2,0 m	10448002	10448202	10448402	10448102	10448302	10448502
Order No. 3,0 m	10448003	10448203	10448403	10448103	10448303	10448503
Order No. 5,0 m	10448005	10448205	10448405	10448105	10448305	10448505
Order No. 10,0 m	10448010	10448210	10448410	10448110	10448310	10448510

Different connector types, combinations and/or cable colors available on request.

High-quality fiber optic patch cords ensure your network operation

The WAVEPACE® fiber optic patch cables are the link between the active technology and the distribution network. These cables are used in many places in the network, such as:

- In the Central Office
- At the Point of Presence (PoP) at highest packing densities
- In outdoor distribution cabinets, like multifunctional or point to multipoint cabinets
- To connect the end customer as part of an FTTH rollout
- In data center environments

The patch cords must therefore always meet the highest requirements, both today and in the future.

The operationally reliable installation during initial connection as well as subsequent service and switching work must be possible safely and trouble-free by all installers, regardless of their level of experience.

The WAVEPACE® high-end patch cords with diameters of 2,0 or 2,8 mm use the most advanced fibers in accordance with the G.657.A2 standard and are assembled with high-quality Grade B connectors. Before delivery, the patch cords are 100% cleaned, tested and individually packaged in the factory.

WAVEPACE® armored patchcords with SM G.657.A2 fiber



10445150
OJS-5,0-SC/APC-SC/APC



Parameter	OJS-xx-SC/APC-SC/APC	OJS-xx-LC/APC-SC/APC	OJS-xx-LC/APC-LC/APC
Patch cord type	Simplex LSZH steel armored customer premises fiber patch cable		
Cable color	White		
Cable diameter [mm]	3,0		
Minimum bending radius [mm]	30		
Insertion loss [dB]	≤ 0,25		
Return loss [dB]	> 65		
Fiber type	SM G657.A2		
Connectors	2 x SC/APC, 8°, Grade B	1 x LC/APC, 1 x SC/APC, 8°, Grade B	2 x LC/APC, 8°, Grade B
Order No. 1,0 m	10445110	10445220	10445260
Order No. 1,5 m	10445115	10445225	10445265
Order No. 3,0 m	10445130	10445230	10445270
Order No. 5,0 m	10445150	10445250	10445275

Different connector types, combinations and/or cable colors available on request.

Undercutting the bending radius is a thing of the past!

Today, many service calls within FTTH networks find its source in the customer in-home network. Experience teaches us, that, apart from unpowered CPEs, in most occasions the fiber patch cord connecting the passive FTU with the fiber CPE is causing the service call.

Everything goes well with the installation, until the time the customer decides to "re-wind" the patch cords with overlength. Most of the time, the customer does not take the fiber patch cord's minimal bending radius into account, and in some cases undercutting the bending radius even causes the fiber to break.

To overcome unnecessary and costly service calls and truck rolls, braun teleCom has designed an **LSZH steel armored patch cord** so robust that bending radius issues or broken fiber cords are things of the past.

During development we learned, that stiff white-colored patch cords, looking like standard RF flyleads, are treated with more care by the customer than the standard yellow ones. For the customer it is more easier to determine that this patch cable is part of the internet and TV services network.

These high-end subscriber patch cables are equipped with high-quality grade B connectors by default, and are 100 % cleaned and tested before leaving our production facility. On request, the patch cords can be delivered with individual labeling, defined by the operator (MOQ 500 pcs).

No more unnecessary and costly truck rolls due to broken fibers!

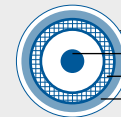

- Outer sheath (white)
- Tight buffer
- Aramid yarn
- Steel armored



Undercutting of the patch cord's bending radius by the customer leads to **unnecessary service calls and broken fibers**.



With our new **high-quality armored patch cords**, costly truck rolls are a thing of the past!

Subject to technical changes!

Pigtails

Singlemode pigtails with LC/APC or SC-APC connector



10448903
OP-LC/APC-bl, 10 Stk.



Parameter	OP-LC/APC-xx												
Application	Single-fiber singlemode pigtail with LC/APC connector and DIN color code for use in connection and termination components, indoor and outdoor												
Fiber type	G.657.A1												
Fiber construction	Ø 9 / 125 / 250 µm; fiber dyed through												
Core construction	LSZH loose tube fiber Ø 900 µm; (Maxi Strip)												
Color code	DIN (IEC 60304), available in 12 colors												
Length [m]	2,0 m												
Ferrule material	Cylindrical ceramic ferrule (zirconia dioxide ferrule / ZrO2)												
Connector pin spring	Corrosion resistant springs with spring ends put on and smoothed												
Connector quality	Classification according to DIN EN IEC 61753-1:2019-10 Grade B / Class B with IL: typ. ≤ 0,12 dB, max. ≤ 0,25 dB (Measurement of the attenuation of randomly mated connectors according to IEC 61300-3-34)												
Attenuation class	Classification according to DIN EN IEC 61753-1: 2019-10: Stage 1 with RL: typ. > 65 dB (required standard: ≥ 60 dB plugged), min ≥ 60 dB (required standard: ≥ 55 dB unplugged) (Measurement of the attenuation of randomly mated connectors and adapters according to IEC 61300-3-6)												
Return loss class	Limiting dimensions of the connector surface according to DIN EN 61755-1												
Optical interfaces	Optical interfaces of fiber optic connectors – part 1: Optical interfaces of non-dispersion shifted single mode fibers – General and guideline (IEC 61755-1:2005)												
Mechanical properties	Fulfillment of requirements according to DIN EN IEC 61753-1 with test method and test severity according to IEC 61300												
Mechanical lifespan	1.000 mating cycles (required standard: 200 cycles)												
Compatibility	Compatible with LC/APC adapters IEC 61753; Can be used with approved crimp, heat shrink, mini HS and mechanical splice protection elements												
Tensile strength	Min. 5 N acc. to IEC 61300-2-4												
Temperature range, storage & transport [°C]	-40 – +70												
Temperature range, operation [°C]	-25 – +70												
Packing quantity [pieces]	10												
Order No.	<table border="1"> <tr> <td>Red: 10448901</td> <td>Green: 10448902</td> <td>Blue: 10448903</td> <td>Yellow: 10448904</td> </tr> <tr> <td>White: 10448905</td> <td>Gray: 10448906</td> <td>Brown: 10448907</td> <td>Violet: 10448908</td> </tr> <tr> <td>Turquoise: 10448909</td> <td>Black: 10448910</td> <td>Orange: 10448911</td> <td>Pink: 10448912</td> </tr> </table>	Red: 10448901	Green: 10448902	Blue: 10448903	Yellow: 10448904	White: 10448905	Gray: 10448906	Brown: 10448907	Violet: 10448908	Turquoise: 10448909	Black: 10448910	Orange: 10448911	Pink: 10448912
Red: 10448901	Green: 10448902	Blue: 10448903	Yellow: 10448904										
White: 10448905	Gray: 10448906	Brown: 10448907	Violet: 10448908										
Turquoise: 10448909	Black: 10448910	Orange: 10448911	Pink: 10448912										

We are happy to also provide the pigtails listed above with SC/APC connectors!

12 pc pigtail sets

Item	Description	Order No.
Pigtail-set-LC/APC-12F-2	Pigtail set LC/APC, 12 colors acc. to DIN color code, SM at G.657.A1 fiber, length 2 m, 900 µm, connector grade B	10445938
Pigtail-set-SC/APC-12F-2	Pigtail set SC/APC, 12 colors acc. to DIN color code, SM at G.657.A1 fiber, length 2 m, 900 µm, connector grade B	10445936
OPT-2-LC/APC-E9U-TB3	Pigtail set LC/APC, 12 colors acc. to DIN color code, SSMF-28 Ultra TB3 fiber, length 2 m, 900 µm, LSZH	10445952
OPT-2-SC/APC-E9U-TB3	Pigtail set SC/APC, 12 colors acc. to DIN color code, SSMF-28 Ultra TB3 fiber, length 2 m, 900 µm, LSZH	10445962

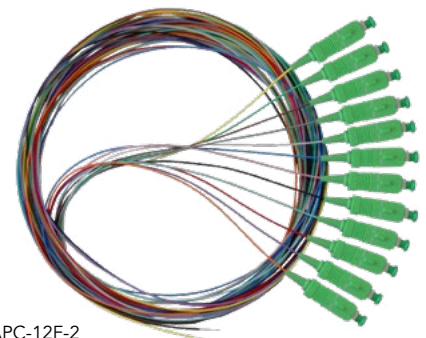

10445936
Pigtail-set-SC/APC-12F-2

Adapters and attenuators

Optical adapters and attenuators, SC/APC and LC/APC



10444000
OAD-SSA-P



10444500
OAD-LCA-P



10442110
OATC-10-All-Band-
Window-SC/APC

Optical adapters

- Very low through loss
- High-precision alignment and stability
- Qualified according Telcordia standard
- Versions available with and without flange or laser shutter

Parameter	SC/APC-Simplex-Adapter	SC/APC-Simplex-Adapter-Shutter	OAD-SSA-P-(SC/APC-plastic)	SC/APC-Duplex-Adapter	LC/APC-Duplex-Adapter	LC/APC-Duplex-Adapter-Flange	LC/APC-Duplex-Adapter-Shutter	OAD-LCA-P-(LC/APC-plastic)	LC/APC-Quad-Adapter	OAD-E2000-P
Type	SC/APC Simplex			SC/APC Duplex	LC/APC Duplex			LC/APC Quad	E2000	
Hook color code	Green									
Through loss [dB max.]	0,2									
Sleeve material	ZrO ₂ (Zirkonia)									
Body material	Plastic									
3 mm flange	No	No	Yes	No	No	Yes	No	Yes	No	Yes
Laser shutter	No	Yes	No	No	No	No	Yes	No	No	No
Temperature range, operation [°C]	-25 – +70									
Temperature range, transport/storage [°C]	-40 – +70	-40 – +70	-40 – +85	-40 – +70	-40 – +70	-40 – +70	-40 – +70	-40 – +85	-40 – +70	-40 – +85
Order No.	10444006	10444011	10444000	10444017	10444007	10444014	10444012	10444500	10444009	10444604

Blind cap SC simplex black

SC blind cap for capping the cavities at a 19" front panel
Order No. 10443441

LC/APC loop back connector

LC/APC duplex loop back connector module with A-B port labeling at the housing; housing color black, dimensions: (L x W x H) 50,9 x 14,4 x 12,0 mm
Order No. 10444055

Optical attenuators (male-female-type)

- Precise attenuation values
- Excellent uniformity
- Very high return loss
- Highly reliable and stable
- All-band window

Parameter	OATC-10-All-Band-Window-SC/APC	OATC-20-All-Band-Window-SC/APC	OATC-10-All-Band-Window-E2000/APC	OATC-20-All-Band-Window-E2000/APC	OATC-10-All-Band-Window-LC/APC	OATC-20-All-Band-Window-LC/APC
Central wavelength [nm]	1260 ... 1650	1260 ... 1650	1260 ... 1650	1260 ... 1650	1260 ... 1650	1260 ... 1650
Attenuation tolerance [%]	± 10	± 10	± 10	± 10	± 10	± 10
Operating temperature range [°C]	- 40 ... +75	- 40 ... +75	- 40 ... +75	- 40 ... +75	- 40 ... +75	- 40 ... +75
Attenuation values [dB]	10	20	10	20	10	20
Connector	SC/APC	SC/APC	E2000/APC	E2000	LC/APC	LC/APC
Order No.	10442110	10442120	10442210	10442220	10442310	10442320

If you wish to order adapters with other attenuation values (1 ... 20 dB):

Please replace the last two digits of the Order No. as well as the specification within the item name with an attenuation value of your choice!

Termination boxes for buildings

WAVEPACE® MDU splice patch wallbox



10418990
WAVEPACE® MDU-Wallbox-SP-24



- Wallbox suitable for open access for the network level 3 indoor-termination as well as the connection of single dwelling units
- Robust and compact design
- 3-part modular design, consisting of housing, fiber module and cover; all components can be installed independently of each other
- Fiber module with pivoting patch panel, pull-out adapter holder, splice tray system, fiber management and cable feeds/outlets
- Designed for 48 LC/APC or 24 SC/APC ports and pigtails by means of exchangeable adapter holders
- 6 hinged splice trays with each 12 fibers and a maximum capacity of 72 fibers using optional crimp or heat shrink splice protection elements
- Integrated management for fibers and wires
- Cable feed for cables and cable protection tubes up to Ø 16 mm
- 10 mm entries for optional loop-function of the feeder cable
- 24 outlets with 5 mm diameter for cables or protection tubes for indoor installation
- Storage of up to 4 m slack at the bottom of the fiber module for wires/cables with 2,8 mm diameter
- Cover lock using latch and additional sealing option
- Prepared for a modern identification and access control system based on NFC standard RFID tag acc. to ISO-IEC 14443A on request

Parameter	applies to all Wallbox models on the right
Application	Splice/patch
Dimensions (L x W x D) [mm]	250 x 170 x 90
Protection class	IP55/IK08
Flammability	UL94-V0
Material	Polycarbonate
Color	Grey, RAL 7035
Mounting options	Wall/pole
Feed and outlet options	2 x Ø 16 mm, 2 x Ø 10 mm, 24 x Ø 5 mm
Cable feed	Bottom
Use of cable and protection tube for blown fiber	Yes
Aperture angle removable cover	180°
Pivot angle patch panel	120°
Angle of the hinged splice tray	70°

Item	Interface	Splice capacity	Special features	Order No.
MDU-Wallbox-SP-empty-Crimp	Patch frame for LC and SC adapters	6 splice trays for 12 x crimp	Depending on splice tray	10418990
MDU-Wallbox-SP-empty-HS	Patch frame for LC and SC adapters	6 splice trays for 12 x heat shrink	Depending on splice tray	10418995
MDU-Wallbox-SP-24-SC/APC-Crimp	24 x SC/APC ports & pigtails	6 splice trays for 12 x crimp	Splitter access at splice tray	10419022
MDU-Wallbox-SP-8-LC/APC-Crimp	8 x LC/APC ports & pigtails			10419040
MDU-Wallbox-SP-12-LC/APC-Crimp	12 x LC/APC ports & pigtails			10419036
MDU-Wallbox-SP-16-LC/APC-Crimp	16 x LC/APC ports & pigtails			10419046
MDU-Wallbox-SP-24-LC/APC-Crimp	24 x LC/APC ports & pigtails			10419026
MDU-Wallbox-SP-24-SC/APC-HS	24 x SC/APC ports & pigtails			6 splice trays for 12 x heat shrink
MDU-Wallbox-SP-24-LC/APC-HS	24 x LC/APC ports & pigtails	-	10419028	

We are happy to also provide the WAVEPACE® MDU wall boxes with different connector versions pre-installed PLC splitters!

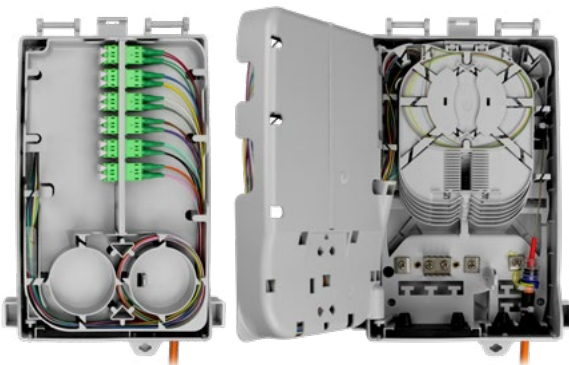

Accessories

Item	Description	Order No.
Adapter-LC/APC-Duplex	Duplex adapter LC/APC with ceramic sleeve, without flange	10444007
Adapter-LC/APC-Quad	Quad adapter LC/APC with ceramic sleeve, without flange	10444009
Adapter-SC/APC	Simplex adapter SC/APC with ceramic sleeve, without flange	10444006
Pigtail-set-LC/APC-12	Pigtail set with 12 fibers LC/APC, SM at G.657.A1 fiber, length 2 m, DIN (IEC60304) color coding, 900 µm	10445938
Pigtail-set-SC/APC-12	Pigtail set with 12 fibers SC/APC, SM at G.657.A1 fiber, length 2 m, DIN (IEC60304) color coding, 900 µm	10445936
Splice-tray-kit-HS-12F	Kit, containing 6 splice trays with holder for heat-shrink splice protection for 12 fibers each	10443958

Application examples of the WAVEPACE® MDU wallbox

Connection of a building, supply of 6 residential units with 4 fibers each

From the OSP cabinet (e.g. the WAVEPACE® Fiber-Cabinet-P2MP), the corresponding fibers will, for example, be routed into the utility room of the building (network level 4). At that location, the WAVEPACE® MDU-Wallbox-SP-24 is already pre-assembled: 4 fibers for each residential unit are spliced from the WAVEPACE® FTTH-WO-4F (a customer premise fiber junction box for 4 fibers) onto the pigtails of the distribution area in an individual splice tray per residential unit.

In the MDU-Wallbox, the fibers from the incoming cable of the OSP-cabinet are now being spliced onto the pigtails of the feeder cable in accordance to the network planning. For example, this can be each one fiber for IP service and one fiber for CATV. The 2 unused, remaining ports of the subscriber in the residential unit are available for other services or a second network operator. Testing and switching can be easily done via the connector interface.

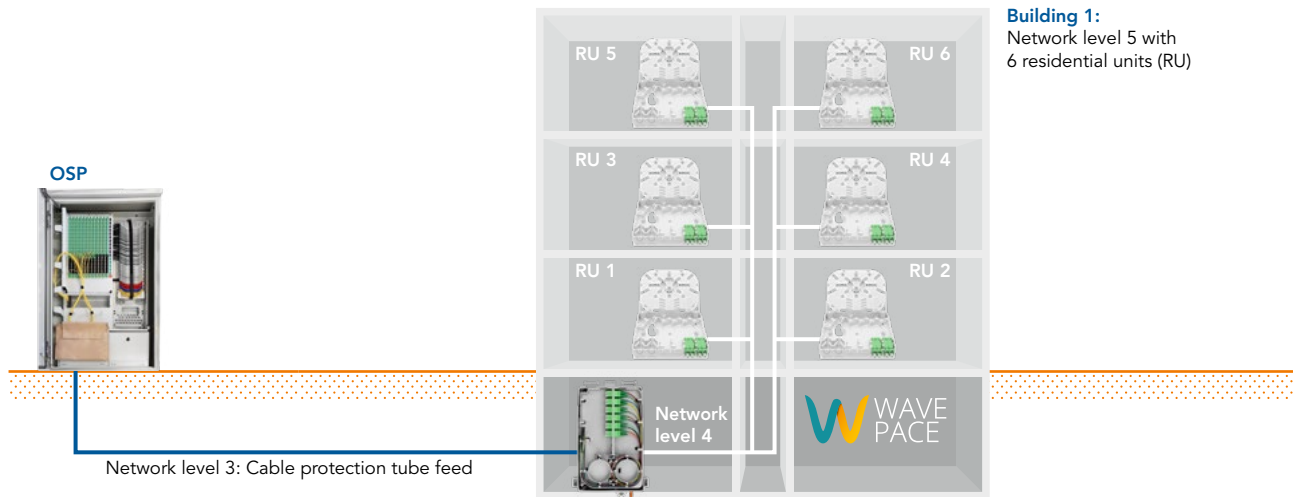

Connection of 2 buildings using Loop function, supply of 6 residential units with 4 fibers each

From the OSP cabinet (e.g. the WAVEPACE® Fiber-Cabinet-P2MP), the corresponding fibers will, for example, be blown into the first building, and are from there being forwarded into the cable protection tube to the next building. During this process, the required loop length will be stored. By a window-cut the cable shall be stripped at the required length and the appropriate buffer tube with the fibers get separated.

protection tube gets terminated at the module, using the installed gas-water seals. Subsequently, the module is re-installed into the wallbox housing.

In the next step, the fibers can be spliced onto the pigtails of the feeder cable according to the network planning. The fibers from the individual residential units can be routed to the wallbox and spliced onto the pigtails of the subscriber part.

For further installation, the fiber module will be taken out of the MDU-Wallbox and the prepared cable will be inserted via the cable feed to perform the loop into the module. The pursuing wires can be stored at the storage area at the bottom of the module. The incoming and forwarded cable

In the second building, the continued cable is to be connected to the respective WAVEPACE® MDU-Wallbox-SP accordingly.

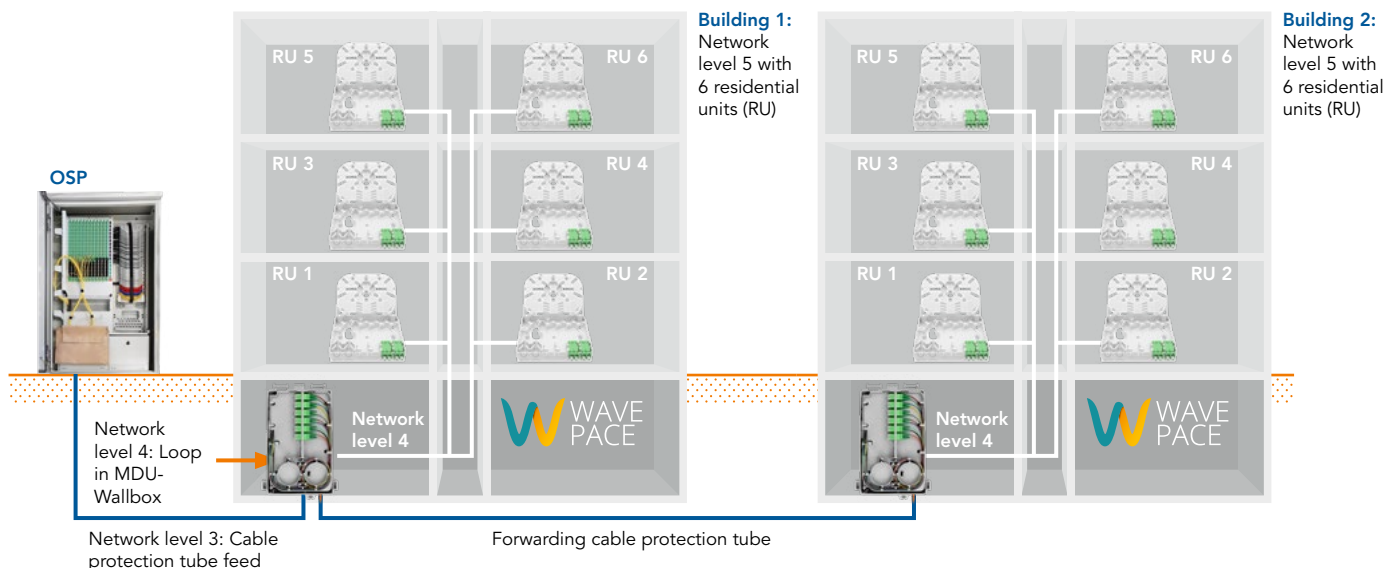

WAVEPACE® MDU splice patch wallbox XL



MDU-XL-Wallbox
closed



- FTTH wall box for indoor and outdoor application
- To be used for network level 3 indoor-termination and in-house distribution
- Robust and compact design
- 2-part modular design, consisting of housing with foldable cover and removeable fiber module including cable feed and clamp
- Accommodates up to 18 LC quad or SC duplex adapters; a patch frame for 48 SC simplex adapters is available optionally
- Very high splicing capacity with 144 fibers in 2 splice blocks, each with 6 splice trays
- Crimp splice trays with integrated splice holder; heat shrink version available upon request
- Fiber module with cable management at the hinged patch area and underneath for fiber routing, for splicing and loop function
- Handling separation through parallel construction for e.g. network level 3 and 4 termination through practical fiber and cable routing
- Locking system

Parameter	MDU-XL-Wallbox-SP-72-Crimp-empty	MDU-XL-Wallbox-SP-72-HS-empty	MDU-XL-Wallbox-SP-72-LC/APC-72-Crimp	MDU-XL-Wallbox-SP-72-SC/APC-48-Crimp	MDU-XL-Wallbox-SP-72-SC/APC-48-HS
Splice protection holder	Crimp	Heat shrink	Crimp	Crimp	Heat shrink
Design	Empty		Pre-installed with 72 LC/APC ports and 72 pigtails	Pre-installed with 48 SC/APC ports and 48 pigtails	
Capacity	72 ports LC (36 SC*) / 144 splices		18 quad adapters LC/APC & 144 splices	48 simplex adapters SC/APC & 144 splices	
Feed and outlet options	2 x (24 x 7 mm) & 2 x 14 mm, with loop functionality				
Cable feed	Bottom with innovative cable/tube interception				
Connector quality	-		Grade B		
Fiber type	-		G.657.A1		
Dimensions (H x W x D) [mm]	360 x 260 x 133				
Protection class	IP 56 / IK 10				
Color	Gray				
Order No.	10419080	10419081	10419087	on request	10419088

* Available with a patch frame for 48 SC simplex adapters on request



MDU-XL-Wallbox
Patch area, pre-installed
exemplarily

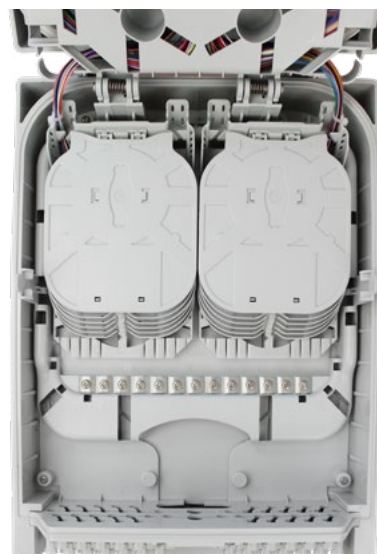

MDU-XL-Wallbox
Splice area

WAVEPACE® 2-door wallbox



10419048
Wallbox-System-2-door-SP-12-
Q-LC/APC-48F

- Compact metal wallbox, powder-coated
- 2 doors with separate locks
- Capacity for 48 LC/APC ports, or as HD version 64 ports with quad adapters and 48 ports SC with simplex adapters
- 6 foldable splice trays for crimp splice protection, to splice up to 72 fibers
- 2 cable feeds and clamps on the left side, each 40 x 73 mm
- Large opening angles for good access
- Hinged door with splice cassettes (e.g. pre-installed to be ready for splicing) can be easily opened to 90° and 180°, allowing installation directly under the ceiling
- Separately accessible patch area with cable feed from below and above by inserting the patch cables
- Completely pre-assembled versions available for quick on-site use
- Boxes can be mounted directly on top of each other for cascading, directly or on a joint support rail
- Open Access suitability
- Indoor application, IP 40

Parameter	Wallbox-System-2-door-SP-12-Q-LC/APC-48F	Wallbox-System-2-door-SP-12-SC/APC-48F-HS	Wallbox-System-2-door-SP-16-Q-LC/APC-64F	Wallbox-System-2-door-SP-12-empty	Wallbox-System-2-door-SP-12-empty-HS
Application	Network level 3 termination (Fiber Access Point) and in-house distribution				
Capacity	12 LC/APC quad adapters, pre-installed with 48 pigtails	48 SC/APC simplex adapters, pre-installed with 48 pigtails	16 LC/APC quad adapters, pre-installed with 64 pigtails	Exchangeable mounting plates for e.g. 12 LC/APC quad adapters and 48 SC/APC simplex adapters, 72 splices	
Splice protection holder	Crimp	Heat shrink	Crimp	Crimp	Heat shrink
Special features	Pre-installed, "ready-to-splice" with pigtails, each 8 fibers inserted into splice trays acc. to DIN color code. Assignment of the splice trays from bottom to top.		Pre-installed, "ready-to-splice" with pigtails, inserted into 6 splice trays acc. to DIN color code, each 12 fibers in trays 1 to 5 and 4 fibers in tray 6. Assignment of the splice trays from bottom to top.		-
Feed and outlet options	2 cable feed blocks on the left side with each 4 x Ø 12 mm, 12 x Ø 7 mm incl. clamp, each 2 patch cable feeds Ø 30 mm on the right side to be inserted from top or bottom				
Dimensions (H x W x D) [mm]	180 x 450 x 150				
Material	Metal, powder-coated				
Color	Light gray, RAL 7035				
Performance	IL: 0,25 dB max., RL: 60 dB min.				
Fiber type	Single Mode G.657.A1, color-coded acc. to DIN (IEC 60304)				
Order No.	10419048	10419045	10419049	10419047	10419044

10419048
Wallbox-System-2-door-SP-12-
Q-LC/APC-48F, opened



Subject to technical changes!

Building Access Terminals for up to 64 residential units

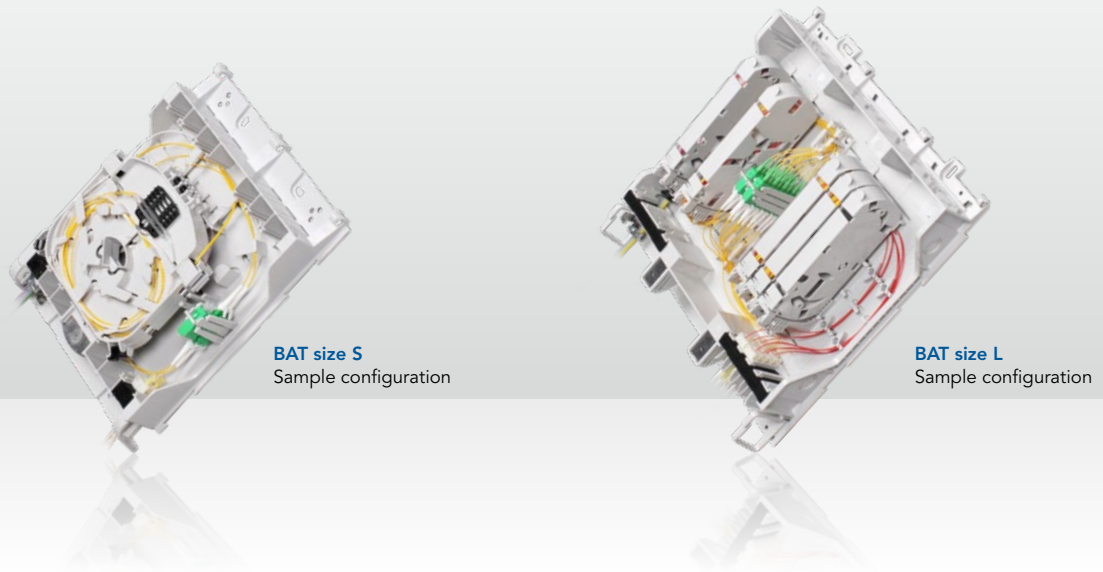

Building access terminal (BAT) is a wall-mountable combination of a fiber termination point for outside plant access cable and a building distribution point in one unit. It ensures a clear separation between outside plant cable, optical devices and building distribution cables. BAT provides a great level of flexibility allowing splitter, splicing, as well as patching applications, and is available in various sizes to address different capacity requirements. Slim, shallow design and rounded housing edges give BAT an unobtrusive appearance.

The housing accepts cables and microducts up to 12 mm outer diameter entering from bottom or top. Foam sealings provide IP55 rating for various cable types, and quick add-ons.

The design of the BAT enables easy access during installation. Multiple units can be placed side-by-side to increase capacity without the need for an additional duct. This also allows separating access for different operators.

The internal components of BAT can be pulled out or rotated for safe and easy access.

The BAT is made of flame-retardant material, making it ideal for MDU applications.

- Available in four sizes (S, M, L and XL)
- UL94, V01 and UV stable material
- Splice, patch and splitter option
- Bottom- or top-entry for microducts or cable up to 12mm
- EMKA lock
- Free of hazardous substances according to RoHS 2011/65/EU

Empty housings and pre-installed boxes

Parameter	BAT-S-HOUSING-EMP/NEUT/G/E	BAT-MGE-ST001	BAT-LGE-ST001	BAT-XGE-ST001
Size	S	M	L	XL
Capacity [residential units]	≤ 3	≤ 12	≤ 16	≤ 64
Dimensions H x W x D [mm]	200 x 250 x 50	240 x 300 x 80	335 x 350 x 88	450 x 390 x 88
EMKA lock included	Yes	Yes	Yes	Yes
Accessories included	2 splice trays, 2 heat shrink splice protection holders, 2 crimp splice protection holders	Empty	Empty	Empty
Housing color	RAL7047 Telegray			
Order No.	80724014	80736350	80740153	80739579

On the following page you will find an extensive selection of modules and accessories for the Building Access Terminals.

We will be happy to assist you in putting together suitable modules!

Accessories for the Building Access Terminals

Strain relief

Item	Type	Application	Suitable for size				Order No.
			S	M	L	XL	
BAT-CDS-01	Strain relief	For cables & tubes up to an outer diameter of 12 mm	•				80726610
BAT-CDM-01	Strain relief	For cables & tubes up to an outer diameter of 12 mm		•			80740082
BAT-CAM-01	Strain relief	For cables with a dielectric central member or branching adapters		•			80789471
BAT-CDL-01	Strain relief	For cables & tubes up to an outer diameter of 12 mm			•		80795395
BAT-CDX-01	Strain relief	For cables & tubes up to an outer diameter of 12 mm				•	80733593

Sealings and sealing modules

Item	Type	Application	Suitable for size				Order No.
			S	M	L	XL	
BAT-CFS-01	Sealing	Ports 1 – 6 for cables & tubes of up to 1 x 12 mm or 2 x 8 mm outer diameter	•				80740831
BAT-CFM-01	Sealing	Ports 1 – 8 for cables & tubes of up to 1 x 12 mm or 4 x 8 mm outer diameter		•			80740958
BAT-CFX-01	Sealing	Ports 1 & 6 for cables & tubes of up to 2 x 12 mm outer diameter				•	80740959
BAT-CFZ-01	Sealing module	For up to 4 x 4 cables with an outer diameter of up to 8 mm			•	•	80740960
BAT-CFY-01	Sealing module	For up to 2 x 2 cables with an outer diameter of up to 8 mm			•	•	80740971
BAT-CFT-01	Sealing module	For up to 2 x 2 cables with an outer diameter of up to 12 mm			•	•	80795730

Splice trays and patch modules

Item	Type	Accessories	Suitable for size				Order No.
			S	M	L	XL	
BAT-PSN-22RT	Patch module	Pre-installed with 2 LC/APC duplex adapters, without pigtails	•				80735097
BAT-PSN-44RT	Patch module	Pre-installed with 2 SC/APC simplex adapters, without pigtails	•				80726651
BAT-PTN-22RT	Patch module	Pre-installed with 2 LC/APC duplex adapters, without pigtails		•	•	•	80775477
BAT-PLN-22RT	Patch module	Pre-installed with 4 LC/APC duplex adapters, without pigtails		•	•	•	80740973
BAT-PTN-44RT	Patch module	Pre-installed with 2 SC/APC simplex adapters, without pigtails		•	•	•	80775478
BAT-PLN-44RT	Patch module	Pre-installed with 4 SC/APC simplex adapters, without pigtails		•	•	•	80743855
BAT-PTY-22RT	Patch module	Pre-installed with 2 LC/APC duplex adapters and 4 pigtails		•	•	•	80775479
BAT-PLY-22RT	Patch module	Pre-installed with 4 LC/APC duplex adapters and 8 pigtails		•	•	•	80762612
BAT-PLY-44RT	Patch module	Pre-installed with 4 SC/APC simplex adapters and 4 pigtails		•	•	•	80768262
BAT-F-01	Splice tray	Includes 1 shrink splice protection holder and 1 crimp splice protection holder		•	•	•	80716780

Splitter modules

Item	Type	Splitter ratio	Input	Output	Suitable for size				Order No.
					S	M	L	XL	
BAT-K4422-102-1	Module with PLC splitter	1:2	SC/APC	LC/APC		•	•	•	80776570
BAT-K4422-104-1	Module with PLC splitter	1:4	SC/APC	LC/APC		•	•	•	80776598
BAT-K4422-108-1	Module with PLC splitter	1:8	SC/APC	LC/APC		•	•	•	80776625
BAT-K4422-116-1	Module with PLC splitter	1:16	SC/APC	LC/APC		•	•	•	80776638
BAT-K0022-116-1	Module with PLC splitter	1:16	Open	LC/APC		•	•	•	80775443
BAT-K4422-132-1	Module with PLC splitter	1:32	SC/APC	LC/APC		•	•	•	80776645
BAT-K4400-132-1	Module with PLC splitter	1:32	SC/APC	Open		•	•	•	80776644

Cable management

Item	Type	Application	Suitable for size				Order No.
			S	M	L	XL	
BAT-R-01	Cable guiding element	Facilitation of cable routing in the housing		•	•	•	80776496
BAT-CC8-01	Cable support	For cables with aramid yarns up to 8 mm outer diameter	•	•	•	•	80775279
BAT-BTS-01	Slack storage	Module for horizontal or vertical installation		•	•	•	80777281

Cable gland

Item	Properties	Suitable for size				Order No.
		S	M	L	XL	
Cable-gland-M25	Light gray RAL 7035, M25 1 x 1,5, without lock nut, packaging unit 50 pcs	•	•	•	•	43000025
Nut-cable-gland-M25	Lock nut for cable gland M25, packaging unit 100 pcs	•	•	•	•	43000026

WAVEPACE® SDU splice patch wallbox



10418994
SDU-Wallbox-SP-S-empty
Front side



10418994
SDU-Wallbox-SP-S-empty
Interior



- FTTH wallbox for indoor and outdoor applications
- Optimally used for single dwelling units as well as multi dwelling units with only few apartments
- Mounting kit consisting of of screws and mounting pins is included
- Protected against dust and splash water according to IP54
- Slim, light and durable housing made of UV stable polycarbonate
- Dedicated space for a gas/water block fitting, to be used with Ø 7 mm micro tubes
- Cable entries for micro tubes with a Ø of 7 mm or 12 mm

Parameter	SDU-Wallbox-SP-S-empty
Splice holder type	Crimp splice protection
Maximal capacity	4 adapters, 12 splices
Dimensions (H x W x D) [mm]	220 x 120 x 28
Protection classes	IP 54, IK-10
Flame resistance	UL94-V0
Weight [kg]	0,25
Color	Grey, RAL 7035
Order No.	10418994



SDU-Wallbox-SP-S-empty
Cover inside



SDU-Wallbox-SP-S-empty
Rear side



SDU-Wallbox-SP-S-empty
Exemplary full occupancy
(not included in scope of supply)

Subject to technical changes!

Termination boxes for apartments

FWO-CS – Flush-mounted fiber optic outlet

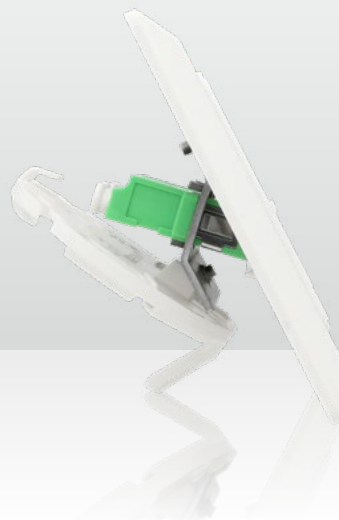

24200602
FWO-CS-LC/APC-2

- Flush-mounted FTTH wall outlet for 4 LC ports
- Installation for a cavity wall box (60 mm mounting dimension)
- Fiber guiding element with splice protection holder for 4 crimp splice protectors
- Guiding contour in the fiber management areas
- Aesthetic appearance and stable design of the 2-part front cover, central plate with hinged adapter panels (dust protection)
- Conically shaped cable clamp for cables up to 3,2 mm diameter with snap-in clamp
- Pre-assembled adapters with single-port laser shutter
- Designed for pigtails with short boot
- Available versions: pre-assembled with adapters and/or pigtails as well as with in-house cable on roll-off carton

Parameter	FWO-CS-LC/APC-2	FWO-CS-LC/APC-2-2F	FWO-CS-xx-LC/APC-4F
Application	Splice/patch		Patch
Interfaces	2 x LC/APC duplex adapters with laser shutter	2 x LC/APC duplex adapters with laser shutter & 2 x pigtails with short boot	2 x LC/APC duplex adapters with laser shutter & 4 x LC/APC connectors attached to pre-installed cable (4 fibers)
Dimensions (L x W x D) [mm]	80 x 80 x 39		
Dimensions central plate [mm]	50 x 50 (DIN 49075)		
Mounting	Cavity wall/switch box (60 mm mounting dimension)		
Outlet material	Frame, central plate and fiber management element: plastic Support plate: aluminum-zinc alloy		
Color	Pure white, glossy surface		
Cable guiding	Cable feed from behind through the cavity wall box to the fiber guiding element		
Adapter quality	Adapter with zirconia sleeve and spring-loaded cover for laser protection (shutter)		
Connector quality	–	Grade B, level 1 classification acc. to DIN EN IEC 61753-1:2019-10 with zirconia ferrule	
Insertion loss IL [dB max.]	–	0,25	
Return loss RL [dB min.]	–	65	
Safety	The frame of the FWO-CS is secured with a concealed screw		
Special features	–	In-house cable Ø 2,65 mm with G.657.A2 fiber, fire protection class B2ca-s1a, d0, a1, for cable lengths see below	
Order No.	24200602	24200604	15 m on request 30 m on request 50 m on request

Please note:

All adapters are also available with internal dust and laser shutters.

Construction and application of the FWO-CS

Construction of the individual elements

- 1 Frame
- 2 Screw cover and labeling field
- 3 Central plate
- 4 Dust covers
- 5 Support plate
- 6 Fiber management element, mounted
- 7 Cable clamps
- 8 LC/APC duplex adapter, mounted



Application examples FWO-CS



FWO-CS-LC/APC-2-F
Pigtail routing

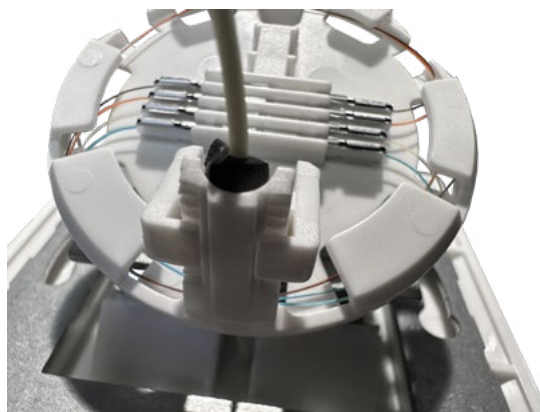

FWO-CS
Wired with micro cable and
4 crimp splice protectors



FWO-CS-LC/APC-2
Adapter access opened

WAVEPACE® wall outlet for the FTTH subscriber connection



10418800
FWO-X1-empty



- Multifunctional junction box with 4 ports LC or 2 ports SC for fiber connection in network level 5
- Extremely compact dimensions 80 x 80 x 29 mm (W x H x D)
- Installation options for cavity wall box (60 mm mounting dimension), wall mounting, DIN rails and as click-on for DIY installation without access to the possibly pre-assembled fiber optics
- Versatile cable entries for all installation cases, from all sides as well as from behind
- 4 adapter positions possible (from freely accessible patch cord connection to fully secured)
- Single port access possible through individual housing cutouts
- Stable and pleasing housing made of white polycarbonate
- Large and free access area due to contour design for safe handling access
- Hinged splice tray with molded universal splice protector holder for crimp, heat shrink or Micro Smouv (Mini HS) splice protectors
- Integration option of reflector elements, also inline for remote service
- Stable bearing of the splice cassette to avoid pressure on the connectors during assembly
- Cable and wire entry opening also allows LC and SC connectors to be fed through
- Available versions: Empty housing, pre-terminated with adapters and/or pigtails and with in-house "pizza box" style cable on roll-off carton
- All pre-assembled adapters provide spring-loaded protection hood (shutter)

Parameter	FWO-X1-empty	FWO-X1-SC/APC-2	FWO-X1-LC/APC-1	FWO-X1-LC/APC-2	FWO-X1-SC/APC-2-2F	FWO-X1-LC/APC-1-2F	FWO-X1-xx-SC/APC-4F	FWO-X1-xx-LC/APC-4F
Application	-	Splice/patch					Patch	
Interface	-	2 x SC/APC simplex adapters	1 x LC/APC duplex adapter	2 x LC/APC duplex adapter	2 x SC/APC simplex adapters & 2 x pigtails	1 x LC/APC duplex adapter & 2 x pigtails	2 x SC/APC simplex adapters & pre-assembled cable (4 fibers)	2 x LC/APC duplex adapters & pre-assembled cable (4 fibers)
Dimensions (H x W x D) [mm]	80 x 80 x 29							
Mounting options	On a cavity wall box (60 mm mounting dimension), wall mounting, DIN rails (horizontal & vertical) and as click-on for DIY installation with pre-assembled fiber optics							
Material wall outlet	Plastic material ABS (LSOH, RoHS, REACH compliant, UI-94V0)							
Color	White							
Cable feed	From the bottom up to 5 mm, up to 4 mm from the top, left and right side and generally from the back							
Adapter quality	-	Adapter with ceramic sleeve and spring-loaded protection hood for dust and laser protection (shutter)						
Connector quality		-	Grade B, Level 1 classification according to DIN EN IEC 61753-1:2019-10 with ceramic ferrule					
Insertion loss IL [dB max.]		-	0,25					
Return loss RL [dB min.]		-	65					
Safety	Cover of the FWO-X1 can additionally be secured with a screw							
Special features	For self-assembly with adapters and pigtails						In-house cable Ø 2,65 mm using G.657.A2 fiber, fire protection class Dca-s2, d2; cable length options see below Non-used 2 fibers are stored in the splice tray	-
Order No.	10418800	10418822	10418820	10418825	10418823	10418821	15 m 10418811 30 m 10418813 50 m 10418815	15 m 10418801 20 m 10418802 30 m 10418803 50 m 10418805 80 m 10418808 100 m 10418809

Details of the WAVEPACE® FWO-X1

Construction of the individual components

- 1 Self-locking cover
- 2 Screw cover, self locking
- 3 Locking screw
- 4 Click-on frame
- 5 Hinged splice tray, mounted
- 6 Basic housing

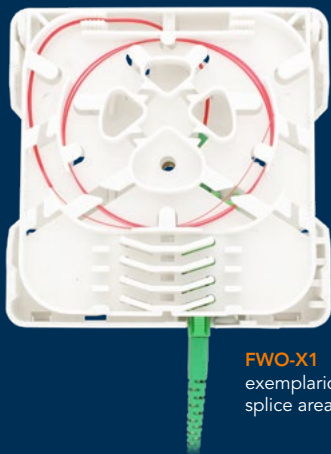
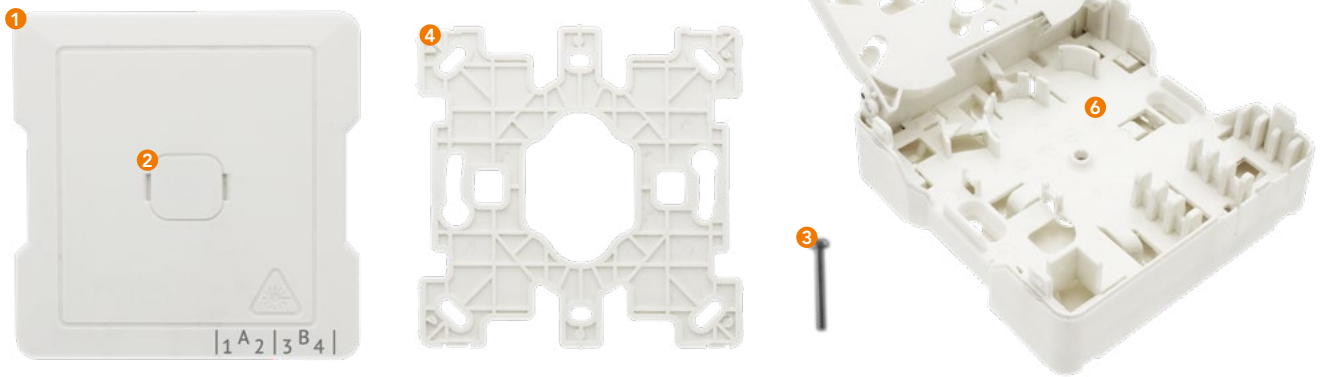

FWO-X1
exemplaric configuration,
splice area

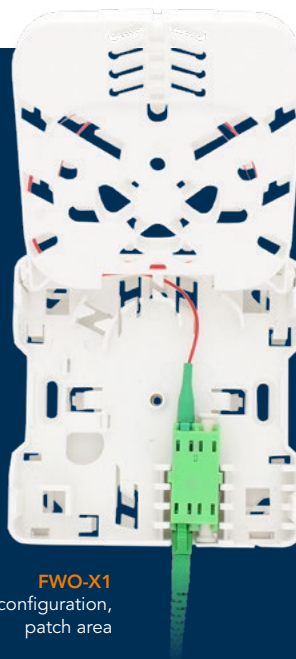

FWO-X1
exemplaric configuration,
patch area



Access restriction
Option to install the connector inside the
outlet to avoid unauthorized access

Further product versions



Special configuration
in accordance with the
specifications of the
German subsidized
fiber optic rollout



**Pre-assembled
"Pizza box"**
With in-house cable
on roll-off carton,
available in different
cable lengths (please
refer to the table)

Subject to technical changes!

FWO-X1-APL-Kit: Accessory set to upgrade the FWO-X1 to an indoor demarcation point box



10444040
FWO-X1-APL-Kit

- Enables the use of the WAVEPACE® FWO-X1 FTTH wall outlet as a indoor demarcation point box for small dwelling units
- 2-part system accessory kit, consisting of support plate and cover for latching on
- Enables the installation of:
 - Up to 2 micro ducts of up to 10 mm with a gas/water blocking system (small design, e.g. ELITEX WGT)
 - Up to 2 adapters LC Duplex or SC Simplex
- Installation options for wall mounting and cavity wall box (60 mm mounting dimension)
- Installation of the FWO-X1 wall outlet by simply clicking the click-on plate onto the support plate or using a screw connection
- Resilient and attractive system made of white polycarbonate, matched to the FWO-X1 FTTH outlet

Parameter	FWO-X1-APL-Kit
Application	Indoor termination box combined with the FWO-X1
Interfaces	2 x micro duct up to Ø 10 mm and/or 2 x LC Duplex adapter / 2 x SC Simplex adapter
Dimensions (L x W x D) [mm]	140 x 80 x 32,5 (Extends the dimensions of FWO-X1 from 80 x 80 x 29 in die relevant area by 60 x 40 mm (L x W))
Mounting options	Direct wall mounting, with screws up to 3 mm diameter or cavity wall box (60 mm mounting dimension)
Material wall outlet	Plastic ABS (LSOH, RoHS, REACH compliant, UL-94V0)
Color	White
Entries	Pre-punched
Packing quantity	Individually packed in bags and 10 pieces in a box
Order No.	10444040

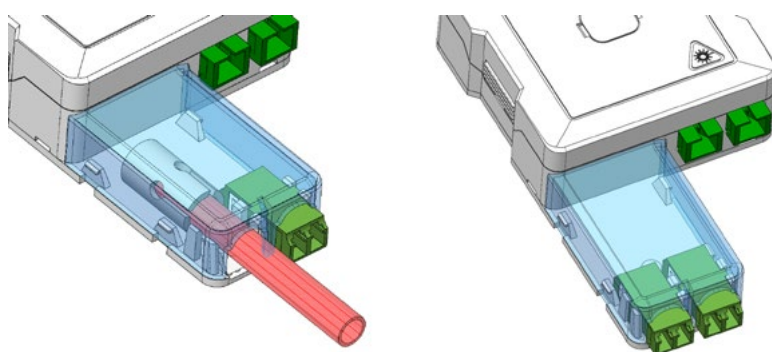

Application examples of the FWO-X1-APL-Kit

The FWO-X1-APL-Kit is compatible with all WAVEPACE® FWO-X1 FTTH subscriber outlets, e.g.:

Parameter	FWO-X1-empty	FWO-X1-SC/APC-2	FWO-X1-LC/APC-1	FWO-X1-SC/APC-2-2F	FWO-X1-LC/APC-1-2F
Application	Universal	Splice/patch	Splice/patch	Splice/patch	Splice/patch
Interfaces	-	2 x SC/APC-Simplex adapter	1 x LC/APC-Duplex adapter	2 x SC/APC-Simplex adapter & 2 x pigtail	1 x LC/APC-Duplex adapter & 2 x pigtail
Compatible with FWO-X1-APL-Kit	Yes	Yes	Yes	Yes	Yes
Order No.	10418800	10418822	10418820	10418823	10418821

Subject to technical changes!

Fiber Termination Units

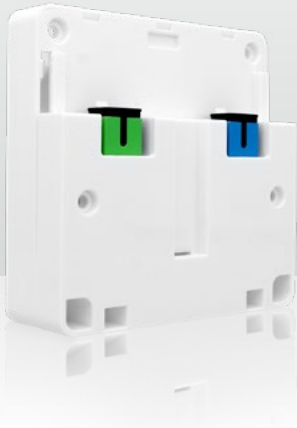

84179716
FTTH-0F-BASE-PC/APC-2,
image without protective cover



84179716
FTTH-0F-BASE-PC/APC-2,
image with protective cover

The most flexible FTUs in the industry

The DKT FTUs consist of a fiber tray/splice module, a click-on adapter module (with SC/APC, SC/PC or SC/UPC adapters included) and a protective cover mounted on top. When using a DKT Gateway, the protective cover is removed and the gateway is plugged onto the FTU.

In this way, the solution functions either as a passive FTTH outlet to which active third-party hardware can be connected without any problems, or as an active fiber optic termination in combination with a DKT Gateway, the so-called 2-box solution.

The simple click-on interface enables activation by the end customer and therefore significantly reduces the network operator's operating costs. The combination of FTU and e.g. 1 Gbps gateway is very space-saving with 88 x 88 x 65 mm and is therefore perceived as "just another outlet" by the customer.

Parameter	FTTH-0F-SMALL-PC/APC	FTTH-0F-BASE-TRAY	FTTH-0F-BASE-PC/APC	FTTH-0F-BASE-PC/APC-2	FTTH-2F-BASE-PC/APC-2	FTTH-2F-BASE-CC-NOR
Splice tray included	No	Yes, large version	Yes, regular-sized version			
Slack storage capacity in splice tray	-	approx. 30 cm of patch cord Ø 3 mm	approx. 150 cm of pigtails, not suitable for storing patch cords			
Dimensions (W x H x D) [mm]	88 x 88 x -/15/23 ¹	88 x 115 x 15/23/35 ¹	88 x 88 x 15/23/35 ¹			
Housing color	white					
Adapter type	SC/APC & SC/PC	SC/APC & SC/UPC	SC/APC & SC/PC			2 x SC/APC
Insertion loss [dB]	≤ 0,20					
Interchangeability [dB]	≤ 0,20					
Repeatability [dB]	≤ 0,20					
Mechanical durability	≥ 1.000 cycles					
Operating temperature range [°C]	-40 – +80					
Sleeve material	Zirconia					
Pigtails	-				SC/APC & SC/PC	2 x SC/APC
Fiber type	-				G.657.A1	
Fiber length [mm]	-				750	
Fiber diameter [µm]	-				900	
Fiber color	-				white	
Item number DKT	79717	79712	79715	79716	79718	79720
Order No.	84020717	84179712	84179715	84179716	84020718	84020720

¹ Depth: splice tray / splice tray including adapter module / splice tray including adapter module and protective cover



Splice tray, regular version
Image without adapter module and protection cover



Splice tray, large version
Image without adapter module and protection cover

Are you looking for the perfect companion for the DKT FTUs?

You will find matching Gateways / ONTs in our range of active optical components!

Closures

Inline and connecting closures

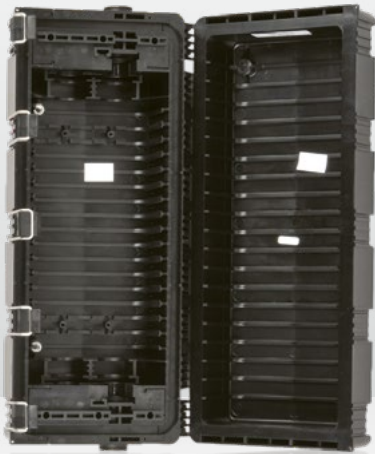

80313269
UCAO-4-9, open



42600305
FDM1, closed

UCAO inline closure for up to 7 MFT splice trays

- Suitable for buried, duct and aerial lines
- For straight and branching application
- Fast and easy access to individual splice trays
- Closure sealing made of re-usable silicone
- Excellent cable strain relief and space for slack buffer tube storage
- To be installed with all common cable sheaths
- Compact design, therefore ideal for splicing cables with low to medium fiber counts
- The body of the closure consists of two half shells made of plastic that is resistant against common environmental influences
- To accommodate cables with up to a 21 mm diameter

Parameter	UCAO-4-9
Closure shape	Inline
Crimp splice count per tray	24
Distribution cable port count	2
Distribution cable Ø range [mm]	6 – 21
Extra buffer storage system	Installed
Grounding system	Metric
Heat shrink splice count per MFT tray	24
Heat shrink splice protector support	Yes
Main cable circular port count	2
Main cable diameter [mm]	8
Max. number of trays	7 MFT
Maximum splice fiber capacity	168
Maximum tray count	7
Number of distribution/drop cables ports	4
Sealing type	Compression fittings
Size by fiber splice capacity	168
SplicePak splice count per tray	12
Supported cables	Flat drop cable Figure-8 drop cable
Dimensions (W x D x H) [mm]	410 x 160 x 120
Protection class	IP68
Order No.	80313269

Accessories for the UCAO-4-9

Item	Description	Order No.
MFT-splice-tray-10	MFT splice tray for 24 crimp splice protections, black, package with 10 pcs	80302169
MFT-cover-10	Cover for MFT splice tray, package with 10 pcs	80313382

Connecting closure FDM1

- Suitable for connecting fiber optic cables up to 24 fibers
- Designed for direct burial, limited outdoor use (UV)
- Test certificate of the State Testing Institute for Electrical Engineering and Electronics, TGM Vienna, tested according to: IP 68, ÖVE/ÖNORM, EN 60529, Test No.: VA EE 32767
- Scope of delivery:
 - 2-part closure base housing (consisting of upper and lower part) with M16 screw connection
 - 1 splice tray with 1 x 12 (resp. 2 x 12) heat shrink or crimp splice holders
 - 2 cable ties 140 mm
 - 2 assembly wrenches (per carton)
 - 1 assembly instruction

Parameter	FDM1
Dimensions (L x Ø) [mm]	307 x 69
Material	Polypropylene
Sealing	Thermoplastic elastomer, sconabled
Max. splice count	24
Screwing	2 x M16 for cables of 4,5 – 10,0 mm (M 20, 7,0 – 14 mm, M 25, 9,0 – 18 mm, upgradeable)
Temperature range (storage, installation & operation) [°C]	-30 – +65
Tensile strength (inputs) [N]	55
Order No.	42600305



42600305
FDM1, open

Dome closures



42400452
ACE-CL-FOC2-AA



42405213
ACE-FOCT-AB-prefab-48x7mm,
closure without tubes

Pre-installed closures „FOCT“

- „Fiber Optic Closure for Tubes“ (FOCT) are pre-installed fiber optic closures for cable protection tube assemblies
- The defined number of micro tubes is divided over the round ports and protected by 3,5 m long flexible tubes
- The tube bundles are firmly connected and sealed to the closure body at the factory
- Protection of inserted tube ends with end caps against water penetration, outgoing tube assemblies are provided with shrink caps
- The pre-assembled gas and water tight closures are factory tested and delivered with a test and quality document
- Without having to do additional sealing work in the field, customer tubes can be connected immediately and only the feeder cable needs to be inserted with a mechanical oval seal

Parameter	ACE-FOCT-AB-prefab-48x7mm	ACE-FOCT-CC-prefab-96x7mm	ACE-FOCT-AB-prefab-24x10mm	ACE-FOCT-CC-prefab-48x10mm
Dimensions (L x Ø) [mm]	525 x 285	770 x 285	525 x 285	770 x 285
Number of pre-installed tubes	48	96	24	48
Diameter of the pre-installed tubes [mm]	7		10	
Length of the pre-installed tubes [m]	4			
Length of the protection tube [m]	3,5			
Number of SE splice trays included	36	84	36	84
Splice capacity, crimp	432	1.008	432	1.008
Color	Black			
Material	Plastic			
Number of round ports	6	8	6	8
Number of oval ports	1	2	1	2
Temperature range (operation, transport & storage) [°C]	-15 – +45			
Protection class	IP68			
Order No.	42405213	42405216	42405233	42405235

Fiber management closure „FOC2“

Parameter	ACE-CL-FOC2-AA
Dimensions (L x Ø) [mm]	390 x 285
Max. tube diameter [mm]	20
Number of crimp splice trays included	6
Splice capacity per tray	12
Max. splice capacity (by upgrade)	576
Color	Black
Material	Plastic
Number of round ports	6
Round port diameter [mm]	32
Number of oval ports	1
Temperature range (operation, transport & storage) [°C]	-15 – +45
Protection class	IP68
Order No.	42400452

Matching accessory: ACE closure bracket

- Closure bracket for FOCT and FOC2 closures
- Pivotal
- Material: Stainless steel
- Length: 1.760 mm

Order No. 42400451



Installation accessories and splice protection



55680109
Crimp splice protection KSS1

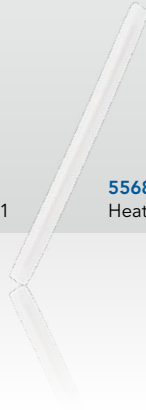

55680118
Heat shrink splice protection



43020006
Ball marker
OMNIMARKER II

Tangit expansion resin M3000

- 2 K expansion resin for fixing gas and water house entries, cable wall entries, and for sealing openings
- 150 ml cartridge – expands to 0,75 l

Order No. 42466150

Trench warning tape

- Trench warning tape "Achtung Glasfaserkabel" (German language)
- 250 m spool

Order No. 42601798

Marking spray DH1040

- Water soluble chalk based marking spray
- Ideally suited for markings which should only be visible for a short time
- Does not cause damage to the marked object
- For indoor and outdoor applications
- Color fluorescent yellow
- Contains 500 ml
- For up to 260 m marking

Order No. 42466500

Marker peg with mount

- Tracking pen for pinpoint locating of lines and splitters
- Includes bracket for mounting the pen to the tube

Order No. 42602424

Ball marker OMNIMARKER II, Orange

- Electronic marking for pinpoint location of buried components
- Locating of position and depth
- Transmits a signal with frequency 101,4 kHz
- Works with all electronic marker locators
- Diameter 100 mm, weight 150 g

Order No. 43020006

Crimp splice protection KSS1

- TSON crimp splice protection for optical fibers
- Packaging unit: 150 pcs.

Order No. 55680109

Heat shrink splice protection

- 45 x 2,4 mm, with support element
- Packaging unit: 100 pcs.

Order No. 55680118



Crimp splice protection KSS1
Packaging unit with 150 pcs.

Do you have questions concerning our products or want to place an order?

We look forward to your call!
+49 511 757086

Do you already know, which products you need?
shop.brauntelecom.com



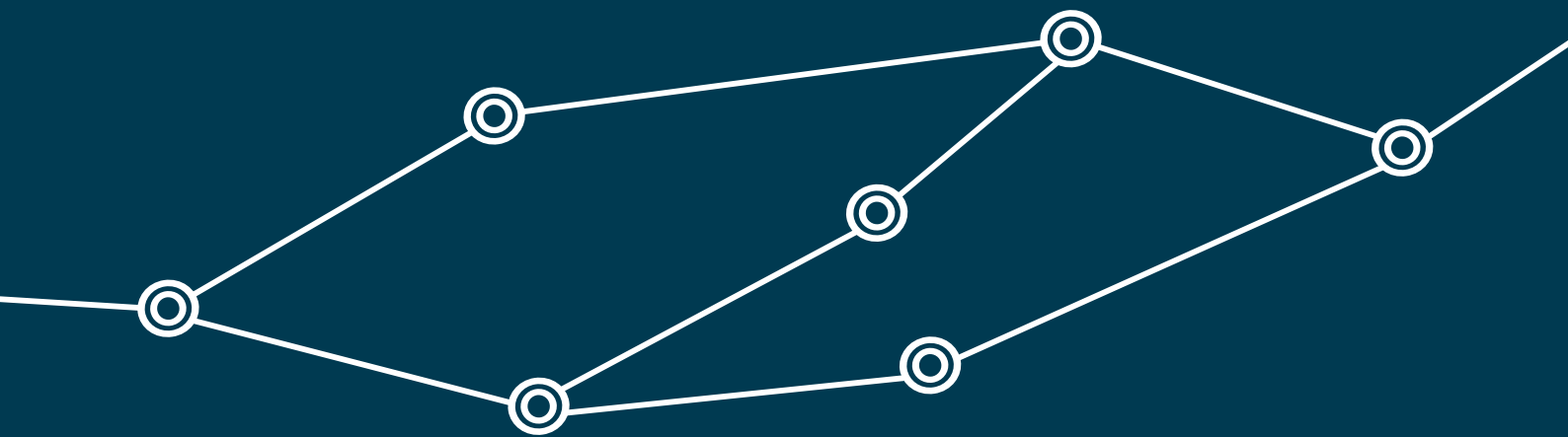

braun teleCom GmbH
Merkurstr. 3 c
30419 Hanover
Germany

Phone +49 511 757086
Fax +40 511 753169
info.de.hannover@netceed.com
www.brauntelecom.com