

Authorized Distribution

a selection of high-quality solutions



braun teleCom products have stood for competence and continuity for more than 35 years. Extensive experience and constantly growing know-how make the components and systems an integral part of many FTTH and HFC broadband networks.

While, in many areas, our activities focus on the development and production of our own products, we also serve as distributor for selected high-performance partners to achieve best possible customer satisfaction.

braun teleCom is a product brand of Netceed. We are a global leader in distribution, logistics, technical engineering, and product design with over 30 years of expertise and performance supporting the telecommunications and broadband industry.

Netceed is a global leader in distribution, logistics, technical engineering, and product design supporting the telecommunications and broadband industry. We supply and distribute a comprehensive range of passive and active equipment and tooling for network deployment, upgrades, and maintenance, supporting all technologies including FTTH, FTTx, HFC, Wi-Fi, 5G/mobile, and data center.

Netceed's comprehensive portfolio of 90,000+ products from nearly 1,500 industry-leading suppliers, along with their value-added supply chain solutions support carriers' seamless delivery of high-speed Internet, Video, Data, and Voice services to Residential, Business, and Mobile Users.



CONTENT

1. COAXIAL TECHNOLOGY

2. CABINETS AND ACCESSORIES FOR POWER SUPPLY

3. OPTICAL SYSTEMS

4. TOOLS

5. CLICK & GO

6. AUTHORIZED DISTRIBUTION

COMMSCOPE	3
<i>E6000 Converged Edge Router</i>	<i>4</i>
<i>Cable modems DOCSIS® 3.0 and DOCSIS® 3.1</i>	<i>6</i>
<i>CHP Max5000® Headend Optics Platform</i>	<i>7</i>
<i>CH3000 Headend Optics Platform</i>	<i>8</i>
<i>Wireless access points</i>	<i>9</i>
ATX	11
<i>MAXNET II Platinum Series</i>	<i>12</i>
<i>SignalON® Product Series</i>	<i>13</i>
TELESTE	15

COMMSCOPE®

Do you have questions concerning our products or want to place an order?

We look forward to your call!
+49 511 757086

Do you already know, which products you need?
shop.brauntelecom.com

COMMSCOPE®

COMMSCOPE is a global innovator in IP, video and broadband technology. They have continually worked with their customers to transform the experience of entertainment and communications for millions of people across the world.

The people of COMMSCOPE are dedicated to the success of our customers, bringing a passion for invention that has fueled their 60-year history: They

created digital TV, delivered the first wireless broadband gateway and pioneer the standards and pathways for tomorrow's personalized, Ultra HD, multiscreen and cloud services.

Together with COMMSCOPE we are dedicated to meeting today's challenges and preparing for the tasks the future holds. Collaborating with our customers, COMMSCOPE and braun teleCom will continue to solve the most pressing challenges of 21st century communications.

E6000 Converged Edge Router

The COMMSCOPE E6000® Converged Edge Router (CER) is the industry-leading Converged Cable Access Platform (CCAP™). It provides cable service providers unprecedented advances in channel density, power efficiency, and cost savings in a redundant, integrated architecture, designed from the ground up for high availability.

This powerful design enables the convergence of all services (video, high-speed data, and voice) on a single physical connector, delivering savings

in capital and operational expenditures, along with increased operational efficiency. Advances in the platform are enabling operators to provide more bandwidth to their subscribers through additional access technologies and architectures.

Features

Service providers are facing several factors that drive the need for additional bandwidth delivery and the access technologies that are enabled by the E6000 CER:

- Exponential growth in bandwidth demands for both residential and commercial high-speed broadband data services.
- Converging MPEG video services on the CCAP while replacing aging Edge QAM products.
- Migration to IP video distribution services.

The E6000 CER enables a managed approach to this evolution with a combination of software-only density upgrades to existing modules, as well as new modules to unlock even higher densities and additional access technologies. The E6000 CER supports multiple deployment architectures and technologies:

- Integrated CCAP (I-CCAP) for traditional Hybrid Fiber Coax (HFC) networks
- Remote PHY distributed access architecture
- 10G EPON Optical Line Terminal (OLT) support for Fiber to the x (FTTx)

The E6000 Generation 2 (Gen 2) modules (DCAM-2, UCAM-2, RSM-2, and EPFM) deliver additional service group density and greater throughput:

- Substantially increase service group density relative to E6000 Generation 1 modules.
- Facilitate a pay-as-you-grow model with increased channel density per service group, enabled by the application of the appropriate DOCSIS® 3.0 Single Carrier QAM (SC-QAM), DOCSIS® 3.1 OFDM and video licenses.

For service groups where Service Providers want to deploy or migrate to FTTX, the 10G EPON Fiber Module (10G EPFM) can be deployed along with the RSM-2 in the E6000 CER to support XFP-based, non-blocked 10G EPON ports. The 10G EPFM leverages the existing E6000 features as well as DOCSIS® Provisioning of EPON (DPoE) version 2.0 to preserve service provider's DOCSIS®-based back-office provisioning and tools.





Subject to technical changes!

Cable modems DOCSIS® 3.0 and DOCSIS® 3.1

32804008
Cable Modem
TG2492S-CE-85



32100553
Touchstone
TM3402B/CE eMTA



32100614
Cable Modem
CM3200



32101224
Touchstone
TG3442SP



Cable Modem TG2492S-CE-85

- DOCSIS® 3.0 residential gateway with 85 MHz Diplexer, 4-port router, and 2 voice lines with IPv6, DS-Lite and SoftGRE Support
- 1 Gbps downstream support with internal spectrum analyzer
- 24 x 8 channel bonding
- 2 x 2 2.4 MHz 802.11n radio
- 3 x 3 5 MHz 802.11ac high-power radio
- USB 2 host port
- Multi processor technology with a 1,2 GHz Intel Atom Core

Order No. 32804008

Cable Modem CM3200

- High-speed access to the Internet and other online services
- DOCSIS® 3.0 certified and backward compatible
- External AC/DC adapter for reduced product size
- Flexible DS x US channel bonding support (up to 32 x 8)
- DS spectrum analysis, speed test, and LEDs for fast troubleshooting
- Business Services over DOCSIS® (BSoD) support

Order No. 32100614

Touchstone TM3402B/CE eMTA

- DOCSIS® 3.1 home telephony modem
- 4 GigE LAN ports
- 2 x 2 DOCSIS® 3.1 OFDM/OFDMA support
- 32 x 8 DOCSIS® 3.0 SC-QAM channel bonding
- 2 FXS RJ-11 ports with carrier-grade VoIP
- Touchstone Voice Stack
- Switchable upstream support 42 MHz, 85 MHz, 204 MHz
- Switchable downstream support 108 MHz, 258 MHz, 1.002 MHz, 1.218 MHz

Order No. 32100553

Touchstone TG3442SP

- DOCSIS® 3.1 home telephony gateway
- 2 x 192 MHz OFDM (downstream) and 2 x 96 MHz OFDMA (upstream)
- 32 x 8 channel bonding for up to 2,5 Gbps of broadband data
- 2 FXS ports with carrier-grade VoIP
- 4-port gigabit router
- 1 dual band-802.11n- and 1 802.11ac Wave2 wireless access point
- Supports RDK-B based router stack

Order No. 32101224

CHP Max5000® Headend Optics Platform



CHP Max5000® Headend chassis applications converge HFC and digital transport onto a single scalable system, allowing operators to accelerate deployment of VOD, high-speed data, telephony, and other advanced services in a space-saving footprint.

The CHP Max5000 offers 13 module slots in a 2RU chassis: 10 module slots for application modules, 2 for isolated redundant power supplies, and 1 for a local or remote management module. A high-speed shelf interconnect option with a 100 BaseT Ethernet connection provides operators with daisy chaining capability for multiple chassis, while front or rear fiber connection options provide them with installation and maintenance flexibility.

By utilizing CHP Max5000 Headend chassis applications, operators can seamlessly and easily stay in line with future goals, add new services, and strongly position their services against the competition.

CHP Max5000 isolated, load-sharing, redundant power supplies are efficient, switched mode modules that accept either AC or DC input. One power supply supports a completely loaded chassis, while two offer power redundancy that eliminates service interruption if one power supply or line-in feed service fails. The CHP Max5000 provides Universal management through the Craft interface, SNMP with HMS, or remote IP access via a Craft Management Module (CMM) or System Management Module (SMM).

Operators with a large base of active CHP Max5000 Converged Headend Platform can seamlessly and easily transition to any CHP Max5000 application. The addition of new multiwavelength transmitters into the CHP Max5000 portfolio enables operators to maximize their installed fiber assets by multiplying the number of customers that can be serviced for more voice, video, and data services revenues.

Details

- Optimize headend and hub efficiencies with industry leading density and low power consumption of up to 20 transmitters or 40 receivers per 2RU chassis
- Up to 44 full spectrum wavelengths for harvesting new bandwidth through node segmentation
- Support multiple optical architectures including full spectrum, overlay and RFoG
- Integrated optical passives for further reduction of footprint
- DOCSIS® 3.1 support for future capacity expansion to 1,2 GHz downstream, 300 MHz upstream
- Transmitters with variable output reduce need for troublesome optical attenuators and front or rear fiber connection to simplify installation and cable management
- Local/Remote Craft Management (CMM) and System Management (SMM) modules
- Configure, monitor, and manage with CORView™ Element Management System

CH3000 Headend Optics Platform



Evolution not revolution!

The COMMSCOPE CH3000 offers cable operators a headend optics platform featuring maximum flexibility, scalability, high packaging density, reliability, and operational simplicity.

It is a robust and powerful platform for implementing all of today's optical transport architectures and the future-proof chassis system can be quickly reconfigured to support service expansion or topology redeployment.

The high density packaging design makes the CH3000 ideal for applications where rack space is at a premium. The chassis can accommodate a wide variety of both active and passive modules. Modules, depending on their function, may be either half platform depth or full platform depth and single or dual width.

The CH3000 incorporates a unique combination of two patented design features: a mid-plane platform concept and dynamic back plates for all active modules. The chassis mid-plane provides a DC power bus and universal communications bus (supporting local and remote SNMP management) and enables installation of modules from either the front or rear of the chassis, with resulting complete inter-module communication and power for easier deployment, monitoring, and servicing.

Dynamic back plates are easily pre-cabled and installed in the chassis to simplify installation of active modules. Active modules can then be mated with associated back plates to ensure a fast, tool-less interconnection for power, optical, and RF connections. Modules are hot-swappable without disconnecting cables or fibers.

Details

- Innovative future-proof chassis (CH3000)
 - Supports up to 64 quad-density, 16 full-depth, or 32 half-depth modules, in a 13" deep 3RU chassis designed for front or rear module insertion
 - All slots are identical and support any configuration of modules
 - Patented dynamic back plate system features fast, tool-less module changes without touching cables or fibers
 - Integrated chassis control and management with immediate detection of active module alarms
 - Accepts comprehensive lineup of active and passive modules in the same chassis to increase functional density
- DOCSIS® 3.1 support for future capacity expansion to 1,2 GHz downstream, 204 MHz upstream
- Rugged AC and DC power supplies with integrated monitoring and control
- Intelligent network management modules – CX3002 and NI3030
- Configure, monitor, and manage with Opti-Trace® Element Management System

Wireless access points



Indoor and outdoor wireless access points

When connectivity really matters, organizations turn to COMMSCOPE (formerly Ruckus). It offers indoor and outdoor wireless access points to fit just about any budget, performance requirement or deployment scenario. Whether you are challenged with high client density, WiFi-unfriendly building materials or just rising employee or customer expectations, COMMSCOPE's

access points provide secure, reliable access no matter how tough the environment. Every COMMSCOPE Access Point, from the humblest to the boldest, is packed with patented technologies that go beyond the everyday to ensure superior connections and awesome user experiences.

Solutions for higher education

Elevate the student experience with campus WiFi, dorm WiFi, campus switches and campus BYOD.

Retail WiFi solutions

Deliver a great retail WiFi and guest WiFi experience while gaining customer insight with COMMSCOPE Cloud WiFi and SPoT

Solutions for hospitality

Hospitality WiFi, hotel access points and guest access for increased guest satisfaction and loyalty.

Solutions for communication service providers

Managed WiFi services, public WiFi, WiFi hotspots and WiFi offload for service providers, operators.

Solutions for multi-dwelling units

MDU WiFi solutions for apartments, dorms, assisted living and high density housing.

Solutions for small and medium businesses

Easy WLAN management with affordable cloud WiFi and controllerless WiFi for SMB and small business.

Solutions for primary education

Create a digital learning environment with WiFi, onboarding and Chromebook solutions for primary, secondary and K-12 education.

Solutions for Smart Cities

WiFi solutions for connected communities and smart city networks.

Solutions for public venues

Stadium WiFi solutions, outdoor access points, under seat access points for a great fan experience.



Do you have questions concerning our products or want to place an order?

We look forward to your call!
+49 511 757086

Do you already know, which products you need?
shop.brauntelecom.com

MAXNET II Platinum Series



The MAXNET II Platinum Series provides an ultra-dense, fully integrated RF signal management solution. By utilizing the properties of MCX connectors and mini coaxial cables, MAXNET II offers the benefits of the original MAXNET line and more – in a lot less space. The product lineup includes splitting/combining passive modules (16, 8, 6, 4, dual 4-way, and triple 2-way), DC modules, broadcast/narrowcast combiners, diplex filters, MCX to F transition modules, amplifiers, power supplies, RF detector A/B switches and optical receivers.



MAXNET® II

- Ultra-dense MCX connector-based RF/optical signal management platform
- Greater than 200 % rack space savings over legacy management solutions
- Significantly reduces network lash-up complexity by using MCX connectors and miniature coaxial cables
- Generic 3RU chassis houses all module types so that any RF or optical signal management function can be performed
- Patented space-saving design
 - Integrated 8-way splitting function in optical receivers and 8-way narrowcast combining function in optical transmitters takes density to an unprecedented level
- Modules are provisioned for front access to test points, controls, and pad and EQ locations
- Chassis holds up to 24 single-width modules or 12 dual-width modules (any combination of all modules is possible)
- Variety of cable and fiber management options
- Active chassis is provisioned to accommodate monitoring and control over the network (HMS compliant (SNMP v2c) or through a web browser for all active modules in the chassis; email alarm notification is also supported
- DOCSIS® 3.1 and CCAP™ compliant
- High performance specification up to 1.218 MHz
- All active modules are hot-swappable

Module offerings include:

- **Passives:**
 - Splitter/Combiners,
 - DCs,
 - Broadcast/Narrowcast Combiner,
 - Diplex Filter,
 - MCX to F Transition Module
- **Actives:**
 - Amplifiers,
 - Power Supplies,
 - RF Detector A/B Switch,
 - Optical Receivers

SignalON® Product Series



ATX Networks has acquired the RF Wox SignalON® Series RF and L-Band signal management product lines from ADC as of October 30, 2009.

ATX' patented SignalON® Series provides engineers with a variety of products to simplify the headend signal management challenge. The SignalON® Series offers specifications that exceed CATV industry requirements. The line consists of an array of passive and active modules. Including splitters/combiners, directional couplers, L-band splitters, diplex filters, as well as amplifiers, power supplies and RF switch modules.

- High density
- High-quality performance (5 MHz – 1 GHz)
- Patented make-before-break attenuator pad design for hitless signal balancing
- Front access to clear pad covers and patented pad guides
- Test point monitoring on many modules
- Multiple chassis configurations
- Connector options: F and BNC
- Several amplifier offerings
- RF/power redundancy
- 100 % quality control



Subject to technical changes!

TELESTE

Do you have questions concerning our products or want to place an order?

We look forward to your call!
+49 511 757086

Do you already know, which products you need?
shop.brauntelecom.com

TELESTE



Mini CMTS DAH 100

The DAH will extend your IP network over the existing coaxial cabling inside apartment buildings. It supports DOCSIS® 2.0 and 3.0 cable modems and up to 200 subscribers. Typical applications are in FTTB/FTTC networks and at the hospitality market, e.g. hotels. The DAH does not need any special equipment premises, it can simply be installed in street cabinets or basements. Its built-in amplifier and return diplexers make it easy to connect to the existing house network.

- 16 downstream and 4 upstreams channels
- Supported downstream modulations: QAM64, QAM256, QAM1024
- Supported upstream modulations: QPSK, QAM16, QAM64, QAM256
- Capacity of 960 Mbps downstream and 160 Mbps upstream
- Integrated power supply, amplifier and level 2 switch
- Available interfaces: Optical interface SFP slot, Ethernet 2 x GbE copper and Coax PG11
- Encapsulation class IP54
- Telnet, WebGUI and SSH for remote configuration
- USB port for local configuration

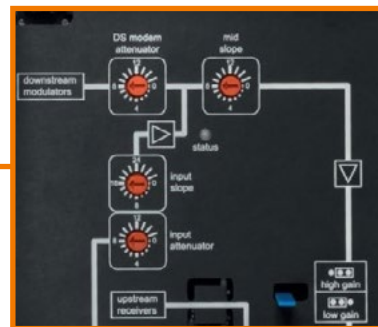

Gigabit Ethernet interfaces:

- 2 x RJ 45 socket
- 1 x SFP module slot

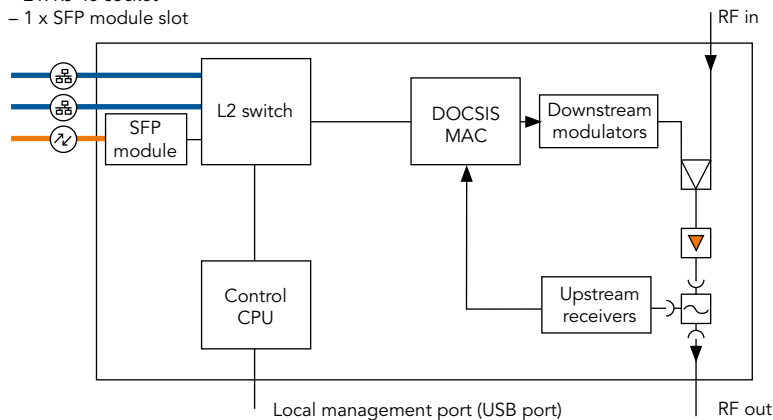

Do you have questions concerning our products or want to place an order?

We look forward to your call!
+49 511 757086

Do you already know, which products you need?
shop.brauntelecom.com



